

Technical information - Technical information	2
.....	2
Technical information - Supplies and accessories	3
.....	3
Operation description - Operation description	3
.....	4
Installation - Heater installation	5
.....	5
Installation - Installation	6
.....	6
Installation - Fastening the device	7
.....	7
Installation - Electrical connections	8
.....	8
Installation - Electrical connections of the device B	9
.....	9
Installation - Water connections	11
.....	11
Control Panel installation - Parts	17
.....	17
Control Panel Installation - Steps	18
.....	18
Fuel connections - Fuel connections	19
.....	19
Fuel connections - Fixed tank connection 30011	21
.....	21
Fuel connections - Selecting the fuel	22
.....	22
Fuel connections - Installation instructions for separate tank connection	23
.....	23
Fuel connections - Tank external filters	24
.....	24
Installation - Solenoid valve	25
.....	25
Exhaust gas connections - Exhaust gas connections coaxial	27
.....	27
Exhaust gas connections - Side lead-through 2467	29
.....	29
Exhaust gas connections - Closable lead-through 2460	31
.....	31
Exhaust gas connections - Stern lead-through 5400	33
.....	33
Exhaust gas connections - Insulation kit	34
.....	34
Controlling the device - Functions	35
.....	35
Operation panel - Controlling the device	36
.....	36
Installation and initial start-up - Check list	47
.....	47
Installation - Bleeding and filling coolant ducting	48
.....	48
Installation - First time start up procedure	51
.....	51
Maintenance - Maintenance recommendations	58
.....	58
Warranty terms - Warranty terms	59

.....	59
<i>Back cover - Wallas - Viking Combi</i>	60
.....	60

Technical information

Fuel	Diesel oil, light furnace oil, HVO-fuel
Operating voltage	12 V DC
Fuel consumption	0,10l-0,25 l/h
Heating power	1,0 kW-2,5 kW
Air	50-90%
Water	10-40%
Power consumption	
Dimensions (L x H x W)	140x424x276 mm
Weight	
Maximum permitted length of exhaust pipe	2m
Maximum permitted length of fuel hose	8m
Maximum permitted length of outlet air duct	
Maximum permitted length of inlet air duct	2m
Minimum area of the replacement air opening	200 cm ²
Warm air connection	90mm
Fresh air connection	90mm
Water connection	19mm
Connections	Solenoid valve Remote control Timer
Suitable Exhaust gas lead-throughs	2467, 2460, 5400

Due to physical laws of thermodynamics, Wallas-Marin announces measured values with 10 % tolerance.

Supplies and accessories

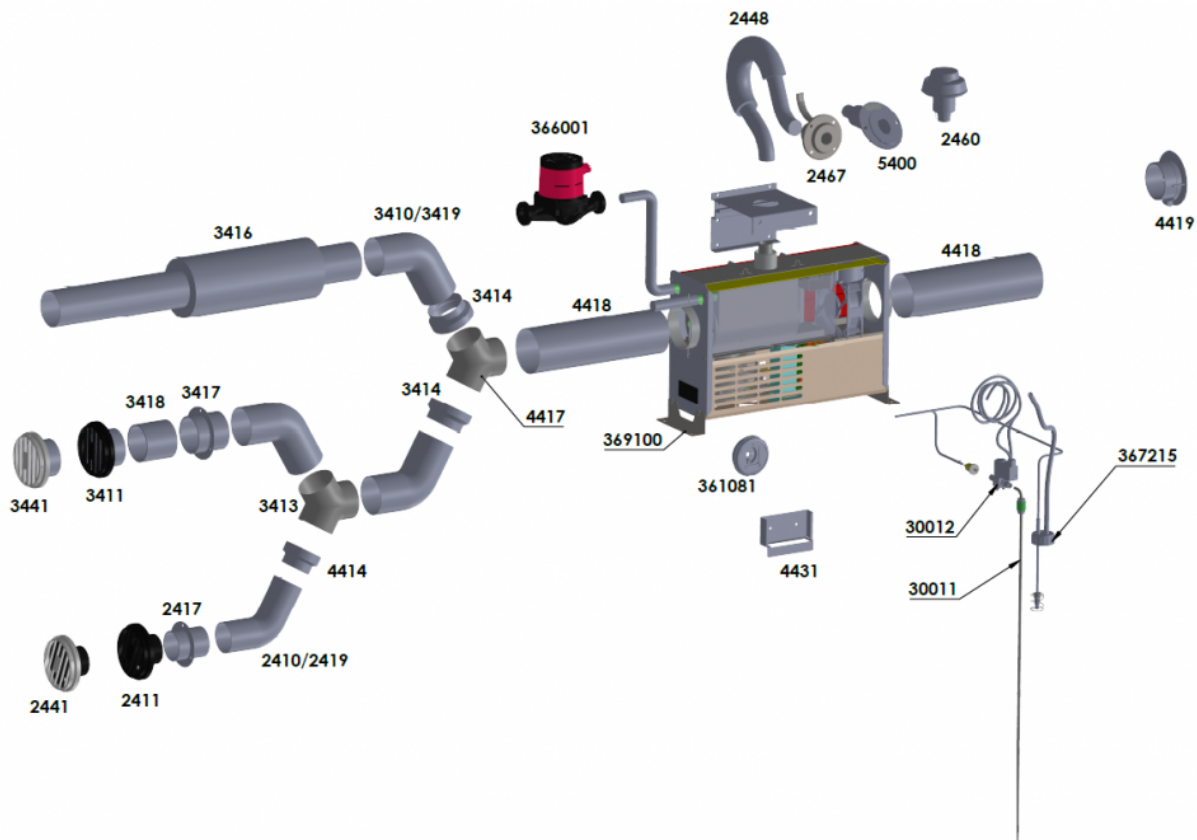

- 2467 Hull lead-through
- 5400 Stern lead-through, 28 / 45 mm
- 2448 Exhaust
- 4418 Warm air duct 90 mm
- 4419 Intake grill 90 mm
- 3410 Warm air duct \varnothing 75 mm
- 3419 Insulated warm air duct d 75 mm
- 2460 Sealable deck lead-through
- 3416 Silencer
- 30012 Magnetic valve 12V/0,5 A
- 30011 Tank fitting / diesel
- 367215 Tank feed through, diesel
- 3413 Warm air 3-way divider 75 mm
- 3414 Duct adapter 75/90 mm
- 4417 Warm air 3-way divider 90 mm
- 3411 Warm air ventilation \varnothing 75 mm
- 3441 Warm air ventilation \varnothing 75 mm, white
- 3417 Bulkhead lead through 75 mm
- 3418 Duct extension 75 mm
- 4414 Duct adapter \varnothing 60/75 mm
- 2419 Insulated warm air duct d 60 mm
- 2410 Warm air duct, 60 mm
- 4431 GSM/GPRS Remote control system
- 2441 Warm air ventilation \varnothing 60 mm, white
- 2411 Warm air ventilation \varnothing 60 mm
- 2417 Bulkhead lead through 60 mm
- 361081 Advanced control panel for XP400
- 366001 Coolant circulation pump

Operation description

Viking Combi heater is forced air diesel heater without an exposed flame. Viking models take combustion air from outside the boat through the outer coaxial exhaust gas pipe and blow their exhaust out through the inner coaxial pipe. The coaxial pipe connects to a common through hull fitting that allows both inlet air and exhaust to pass separately. This process improves efficiency, wind resistance and lowers the minimum power level.

Combi's double function heat exchanger warms up boats cabin and removes any fog from the windshield with heated air while providing warm water for the boiler. Coolant circulation can be attached to heated mats or other additional equipments for extra comfort.

For all these models, fresh makeup air is taken from desired areas with air intake ducting, e.g. from outside of the boat or inside the cabin. This enables good air circulation and cabin air replacement. Diesel engine compartment installations are supported by the separate makeup air intake ducts, quarantining the makeup air away from any smells or noxious engine fumes. The heat generated by forced air fuel combustion, is transferred to the circulation air and water by a heat exchanger. The heating power can be adjusted freely between high and low output settings by manual control or by thermostat. The heated air is circulated through the cabin through the warm air ducting. In hot and/or humid conditions, these heating units can be used for simple fresh air ventilation and circulation.

When starting the device, the glow plug ignites the pumped fuel in the burner bowl. The glow/start and shut down sequences are factory programmed, so - starts and stops are automatically controlled. The fuel pump inside the heater case regulates the fuel feed and the system electronics control both the fuel and air mixture to maintain the ideal clean burning process. The temperature sensor inside the burner feels the ignition and lights up the red signal light (1) to indicate a successful start. When stopping the device, an automatic after cooling process takes place. This process cleans the burner, purging any unburned fuel.

The heaters are completely made out of the best corrosion resistant materials for marine conditions.

Heater installation

Heater installation

Country specific regulations shall be followed in any installation. The warranty of boat products is valid only in installations that are done according to this manual. The device is meant for watercraft use. The warranty is not valid in installations to vehicles or other spaces, ask country specific regulations from local distributor.

Things to note when selecting the installation location

The device shall be installed into a dry space in a protected location. The device must be mounted to a solid, stable bulkhead, floor or wall. When installing, please note that the device needs to be removable for servicing. Connections and location should be made so that the device can be easily disconnected for removal. For maintenance, it is useful to leave 200 mm (7 7/8") empty space below the heater for the removal of the bottom cover of the heater.

The heater should be installed vertically level when the boat is on an even keel. The static inclination must not exceed 5°. While the device will tolerate being temporarily tilted to a steep angle (even for some hours), the burner will not yield optimal performance if it is constantly inclined.

Select the place of installation to allow a minimum amount of bending in the warm air ducting. Avoid installing the heater and control panel in the immediate vicinity of any potential water intrusion. If possible, install the control panel on a vertical surface. We recommend that the device be installed by an authorized Wallas service shop or installer.

Things to note when installing pipes, hoses and cables

Power cables, warm-air and water ducting and fuel hoses must be protected in locations where they are susceptible to mechanical damage due to sharp edges or heat. All cables and hoses should have a fluid precluding "drip loop" to prevent water or other fluids from following wires or hoses to the heater.

Installation space

The device can be installed within the heated space or outside of it. If located unheated area, heating performance can be improved by installing the an intake air tube to the heated space (warm return air). If located inside the heated area, air refreshing performance can be improved by installing the an intake air tube to the outside air (cold, dry fresh air to be heated).

Installation

The necessary installation tools



ø 2 mm
ø 5 / ø 6 mm

PZ 2
PH 2
TX 10

8 mm
12 mm
13 mm

ø 35 / ø 50 mm
ø 76 mm
ø 83 mm
ø 96 mm

In a metal-hulled boat, you must ensure that the device, the exhaust gas lead-through, the fuel connection, the control panel, and all other parts are insulated from the boats hull. This must be done to

1. prevent electrochemical corrosion
2. prevent voltage from being transmitted from the hull to the device or vice versa during electrical faults.

Always use original Wallas accessories and parts with Wallas equipment.

Fastening the device

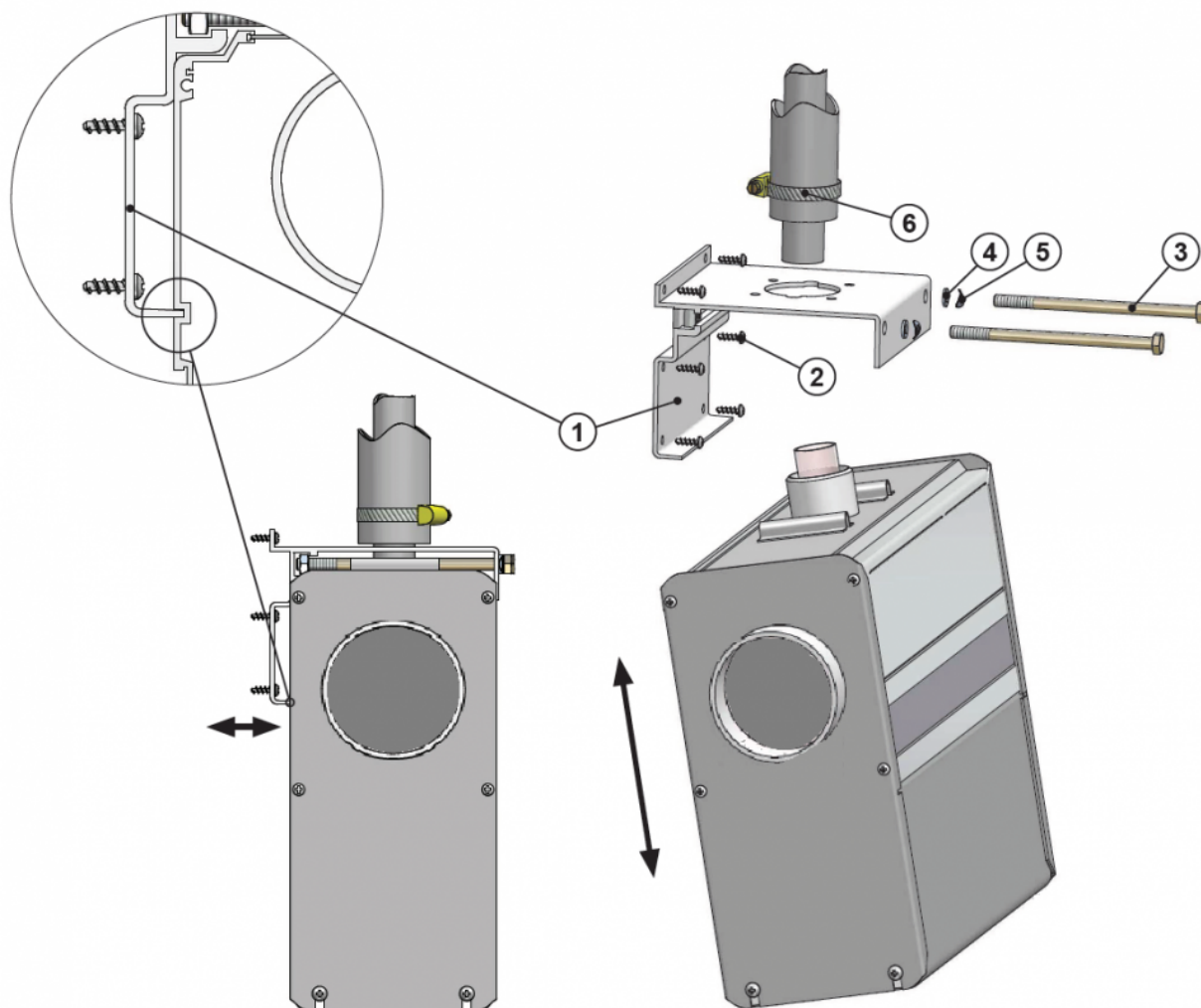

Fastening the device

Fix the mounting plate (1) with screws (2) to a suitable place and check that the bottom of the heater is in horizontal position. Lift the heater into the installation plate and lock the device with the mounting bolts (3). There has to be a washer (4) and a corrugated base plate (5) under the head of the screw. Be sure that the edge of the mounting plate will lock to the slot in the side profile of the heater. Connect the exhaust gas pipe with a hose clamp (6).

Electrical connections

Heater has to be connected up electrically according to the EMC-directives.

Safety instructions for wiring the heater:

- Make sure that electrical cables are not damaged. Avoid: chafing, kinking, jamming or exposure to heat.
- Electrical connections and ground connections must be free of corrosion and firmly connected.
- In waterproof connectors seal any connector chambers not in use with filler plugs to ensure they are waterproof

Things to note about the connections

All connections must be arranged in the craft so that they can function perfectly under normal operating conditions. Insulate unused cable ends.

The device uses 12 V (nominal) direct current voltage. To minimize current losses, make the power cable as short as possible and avoid joining. The cross-sectional area of the cable is dependent on the length of the power cord. The cross-sectional area of the cable must be consistent all the way from the stove to the battery. The maximum length of the power cord is 10 m, based on 6 AWG cable.

The cross-sectional area of the cable

Total length of the power cord (m)	Cross-sectional area of the cable in square mm (US Gauge)
0-4	4 (12 or 11 AWG)
4-6	6 (9 or 8 AWG)
6-10	10 (7 or 6 AWG)

If a thicker cable is required, make a separate joint in the power cord. See picture on the next page.

Electrical connections of the device B

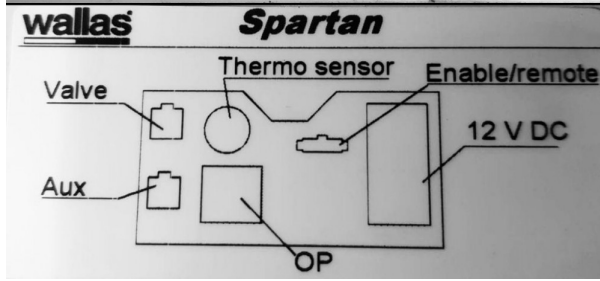
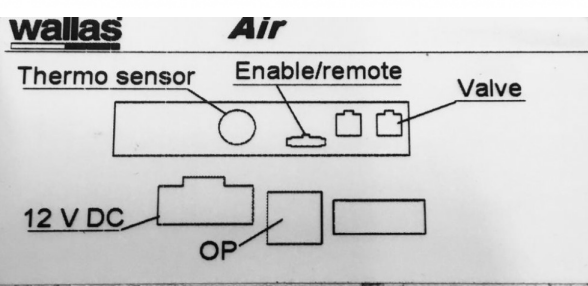
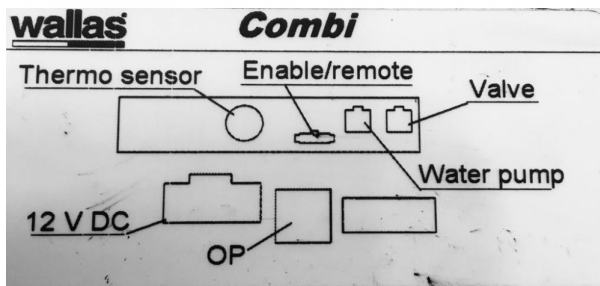
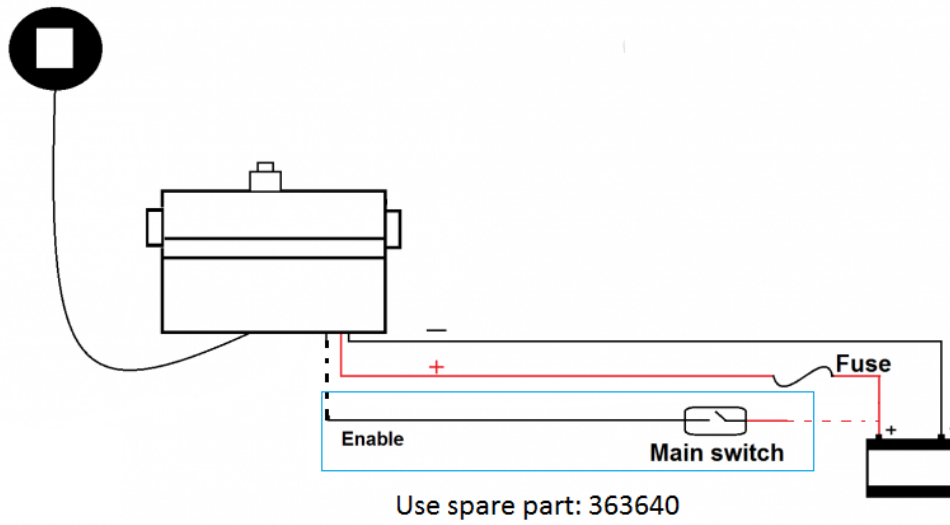

Remote wire 363640 (Sold separately)

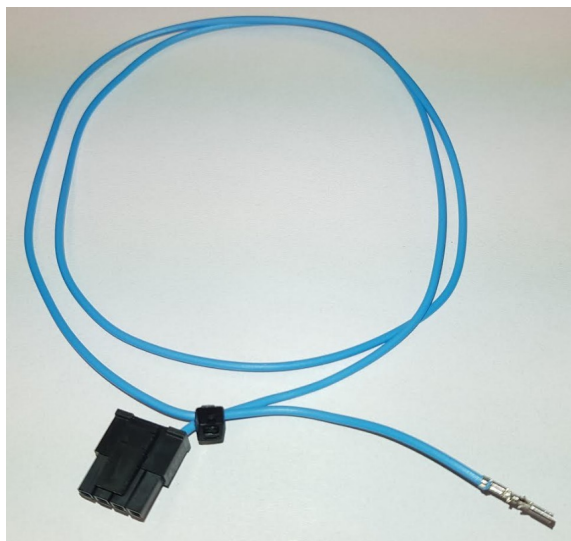

If the heater is needed to be shut down from the boat's main switch, use the spare part **363640** to the heater, and connect the another end of the wire to the main switch. The heat will not start without turning the switch **ON**, and it will perform a controlled shut down when the switch has been turned **OFF**.

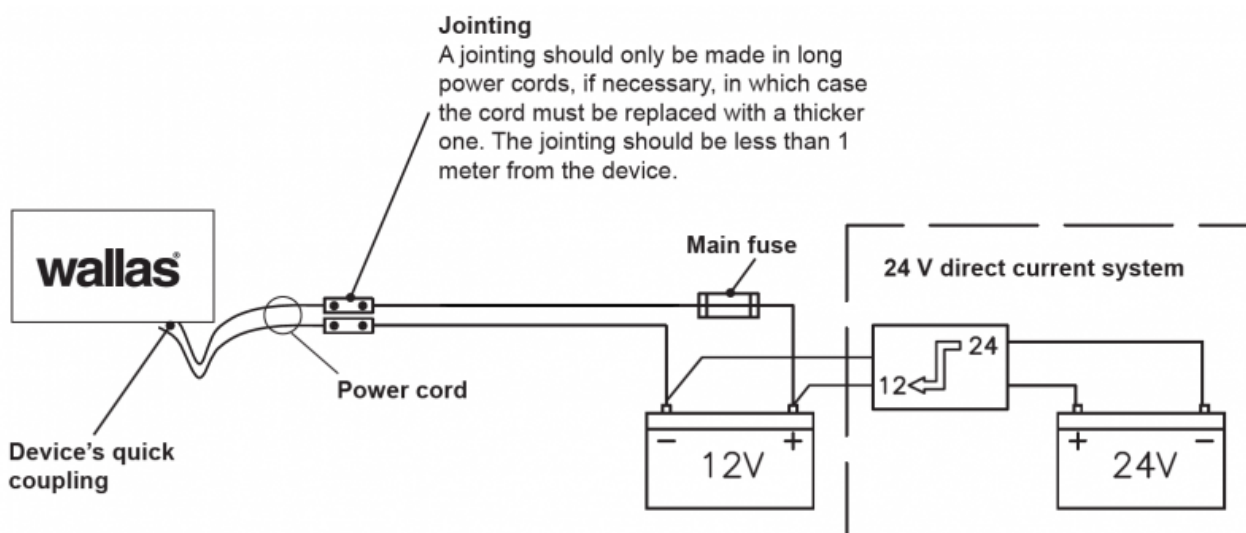

Electrical connections of the device

12 V direct current system

Connect the red wire of the power cord to the plus terminal of the battery and the black or blue wire to the minus terminal. A 15 A main fuse must be installed near the battery on the red plus wire of the power cord. See picture.

Enable wire needs to be connected through boats main switch, when switch is connected the unit wakes up and can be turned on. Enable wire connection protects the unit in case when unit is on and main switch is disconnected, then unit knows that it should turn off but does this controlled and cools the burner before shutting down.

Note that unit doesn't work without 12V voltage to the "remote" pin, so its necessary to connect enable wire to the main switch, or do a enable jumper instructed in section "24V system"

24 V direct current system

If the device is to receive power from a 24 V system, always connect a charging voltage reducer and a 12 V battery before connecting the device.

Without the battery the voltage reducer will not be enough on its own as it cannot generate the large amount of current the glow plug requires.

After the 12 V battery, the connection is the same as in a 12 V system. Note, if using remote wire, the remote wire also needs 12V, not 24V.

Only approved DC DC converter is Victron Orion 2412 - 25A, which can supply enough current without the voltage drop.

Checking the connection

The device consumes most power when it is started up (glowing). At this point voltage losses are also at their highest. During the glowing phase, the voltage must be at least 9,6 V measured at the quick coupling. See picture. If the voltage is lower than this, the device may not start.

All wires needs to be mounted with smooth bending and equipped with strain relief.

Things to note about the connections

While installing, to make mounting and dismounting for service easier, it is recommended to leave some extra length of loose cables and fuel line by creating a coil. If the installation location is cramped, it is recommend to connect the cables and the fuel line to the device before mounting the unit to bracket. This will help the installation of device.

Water connections

Warning

Make sure that parts which where water is involved are installed and placed so that they do not create any burn for skin for human or animal, or it should not harm any heat sensitive material around.

Especialy metal joints are as hot as your coolant (max +85C°).

Before doing any installation or service work for the heater or water system, shut off the heater and let the system cool down to prevent any burn skin.

Note!

- Pump needs to be installed before the heater so the pump is working with coolest coolant in the system.
- Make sure that the flow direction is correct in your installation.
- Route all the water hoses so that they are rising from the lowest point to higher. This will prevent air locks from the system.
- Follow the bending radius recommendations to prevent clogging.

- Make sure that the water hoses are far enough from the hot metals such as engine.
- Water hoses and fuel lines must be protected in locations where they are susceptible to mechanical damage due to sharp edges or heat.
- Double check all the hose clamps and joints to prevent any leakages.
- Make sure that the temperature difference between the inlet and outlet of the water is never over 10 Celcius. This makes sure that the water flow through the whole system is sufficient.
- The heater is designed to be used with the open header tank. The system should not be pressurized. The maximum pressure of the system 0,5 bar.
- To prevent corrosion, the hot water system has to contain at least 10% antifreeze/coolant liquid (recommended 30%)
- To prevent freezing hot water system has to contain enough antifreeze/coolant liquid
- Before first start up, or after liquid change system needs to be bleed. If the system is not air free the system will not work as designed.
- When choosing the size of a header tank make sure that volume of the tank is large enough. With 19mm hose every 10m with 64 Celcius temperature difference volume increases 4 cl. With 21mm hose volume difference is 5cl in every 10 metres.

Hosing diagram

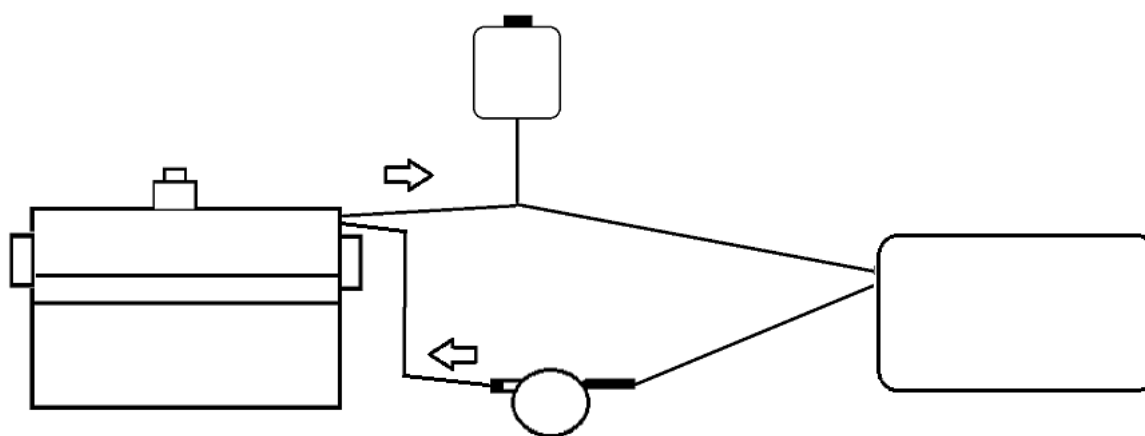
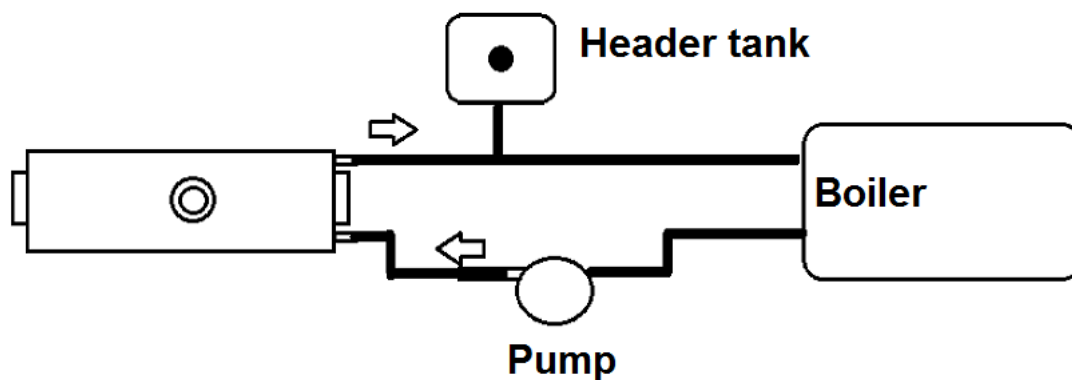

Hoses have to be rising all way around the system. Header tank needs to be uppermost part of the system. This kind of hosing makes possible air bubbles to escape through header tank and there will no be air locks.

Correct outlet from heater.

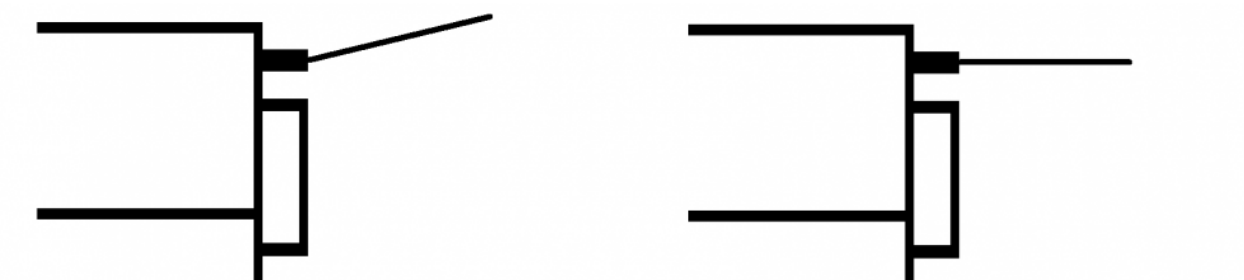

Not allowed outlet hosing!

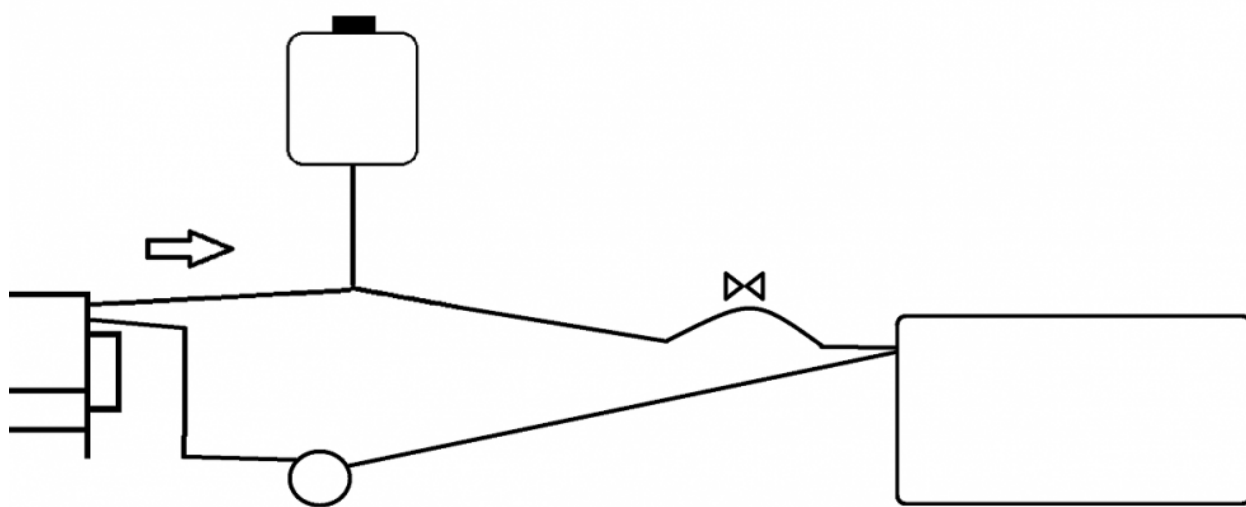
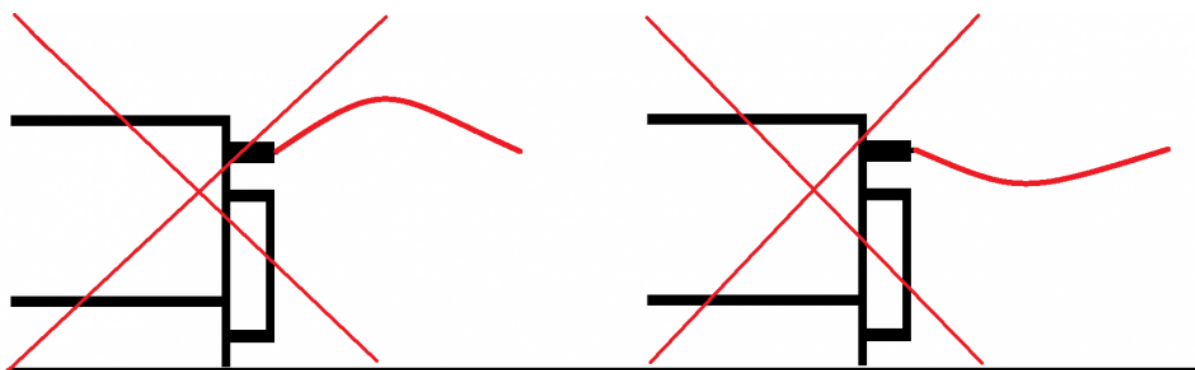

If its not possible to install hoses as suggested, its mandatory to install air bleed valves all parts of system where is risk for air lock.

Water pump installation

The water pump must be installed horizontally.



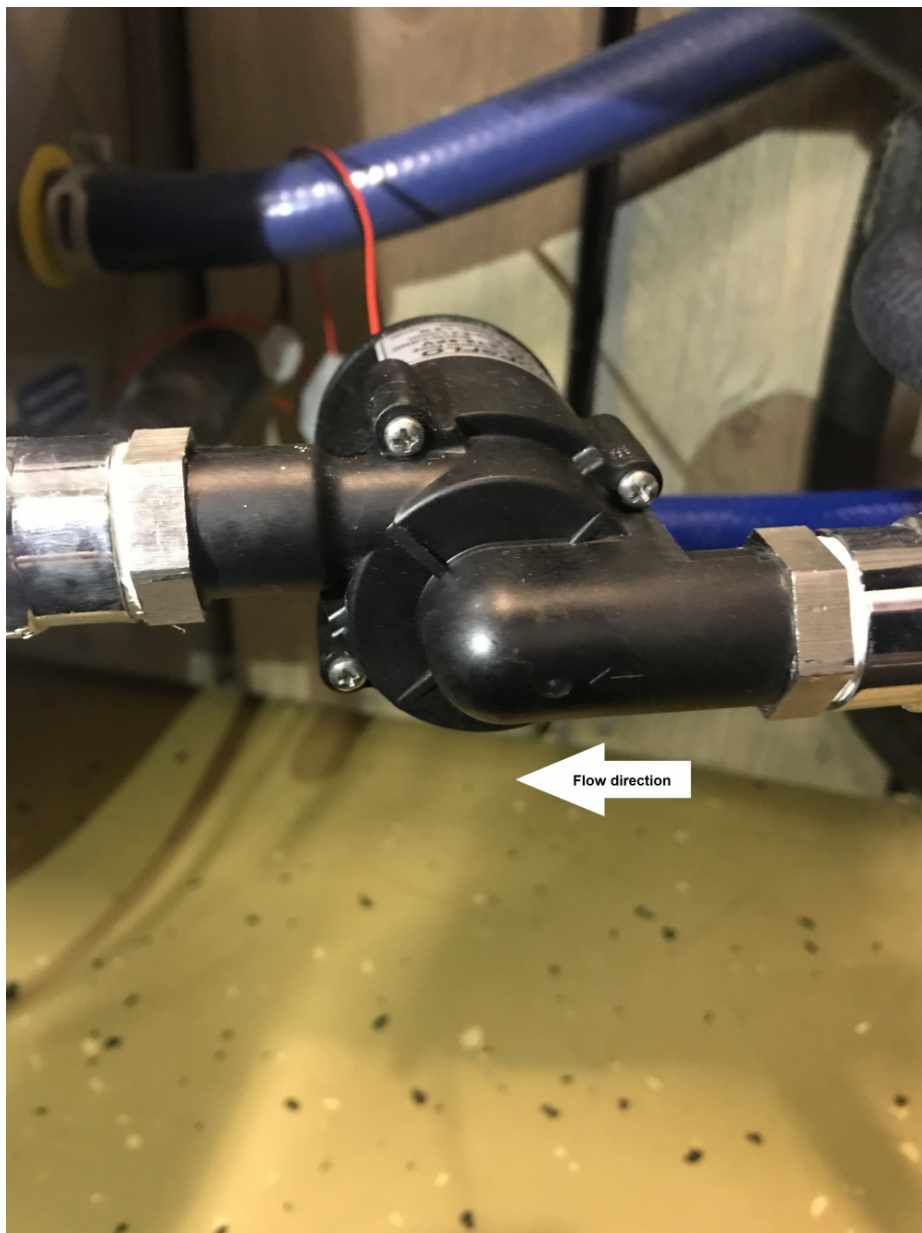

Arrow printed to the side of pump indicates flow direction.

Parts

Installation

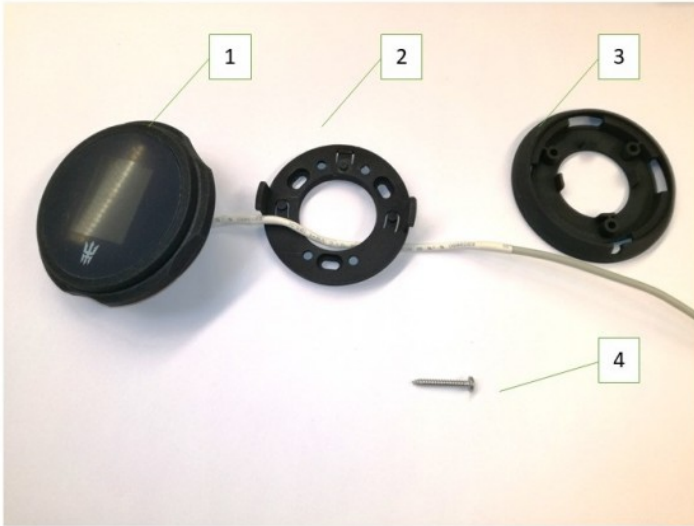

- 1. Control panel
- 2. Assembly plate
- 3. Wall assembly
- 4. 3pcs

29.6.2018

Control Panel installation

Steps



Step 1: Install cable into Wall assembly plate.

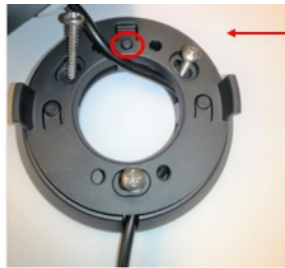

Note!
Pin position

Step 3: Install screws 3 pcs
Pull carefully extra cable out .



Step 5: Connect cable into heater.
Start using :- rotate wheel
-select by pressing top of panel

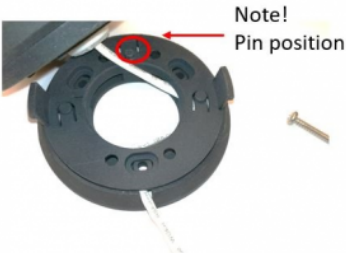

Note!
Pin position

Step 2: Install assembly plate



Step 4: Snap Control panel

Hole assembly.
Note you may assembly without Wall assembly plate if you drill opening for Cable. Min 24 mm to allow free movement for cable rubber.

20.12.2018

Control Panel installation

Fuel connections

Things to note about the connections

The standard length of the fuel hose is 4 m (max 8 m). Cut the fuel hose to a length suitable for installation.

The lift height of the pump should be less than 2 m; preferably 0.5-1 m. The fuel pipe must always have a Wallas filter.

The fuel filter can be installed either near the device, near the tank, or in another location where it can be easily checked and replaced, when necessary.

Diesel engine fuel filters and/or separators are not approved for use. All soft connections should be made with rubber or silicone hose which is resistant to fuel.

Connection to a heater

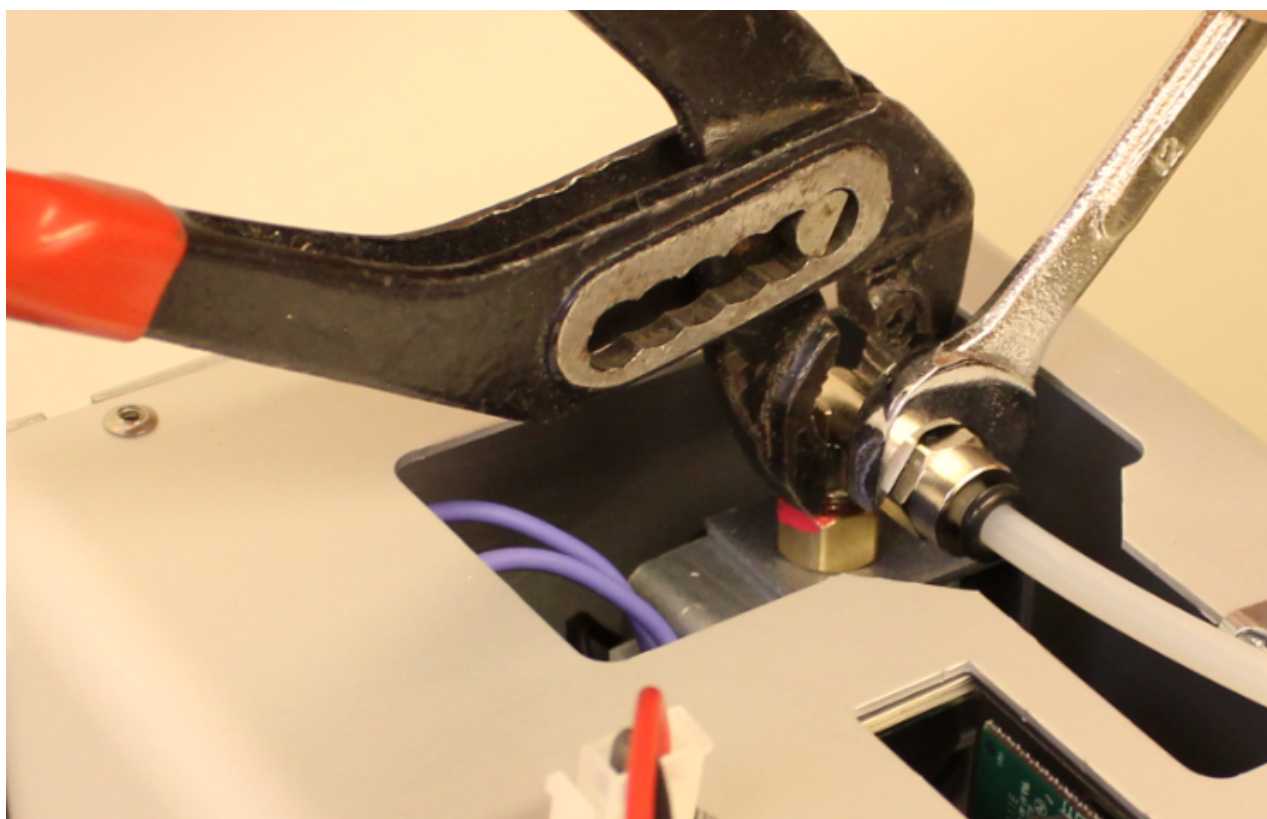

Use pliers to hold the pump inlet elbow steady, while you tighten the 12 mm fuel line nut. The joint has to be very tight to prevent air leaks.

Tightening torque is 19Nm.

Country-specific requirements

The standard fuel hose is plastic. Please observe country-specific requirements with regard to the material of the fuel hose/pipe and the fuel filter. The inner diameter of a new replacement hose should be equal to the inner diameter of the plastic hose. Copper pipe **300692** and metal filters **30016** are available as accessories. Ask local requirements from your distributor.

Fuel feed

If the lift height exceeds 2 m, the fuel feed must be checked and, if necessary, adjusted.

The fuel feed must also always be checked, if parts of the fuel system, such as the pump or the electronics card, have been replaced. Fuel system adjustments are device specific. These adjustments should only be carried out by an authorized service shop.

Connection to a fixed tank

The device must have a dedicated connection with a fuel filter outside the tank.

Connection to a separate tank

Cap run-throughs and sintered filters are used on plastic tanks. The fuel tank should be mounted securely.

Wallas fuel tanks

Volume	Lenght x height x width	Order code	
5l	200 x 300 x 130 mm	2024	(accessory)
10l	380 x 195 x 210 mm	2027	(accessory)
33 l	500 x 235 x 355 mm	4030	(accessory)
130 l	800 x 400 x 600 mm	4130	(accessory)

Fixed tank connection 30011

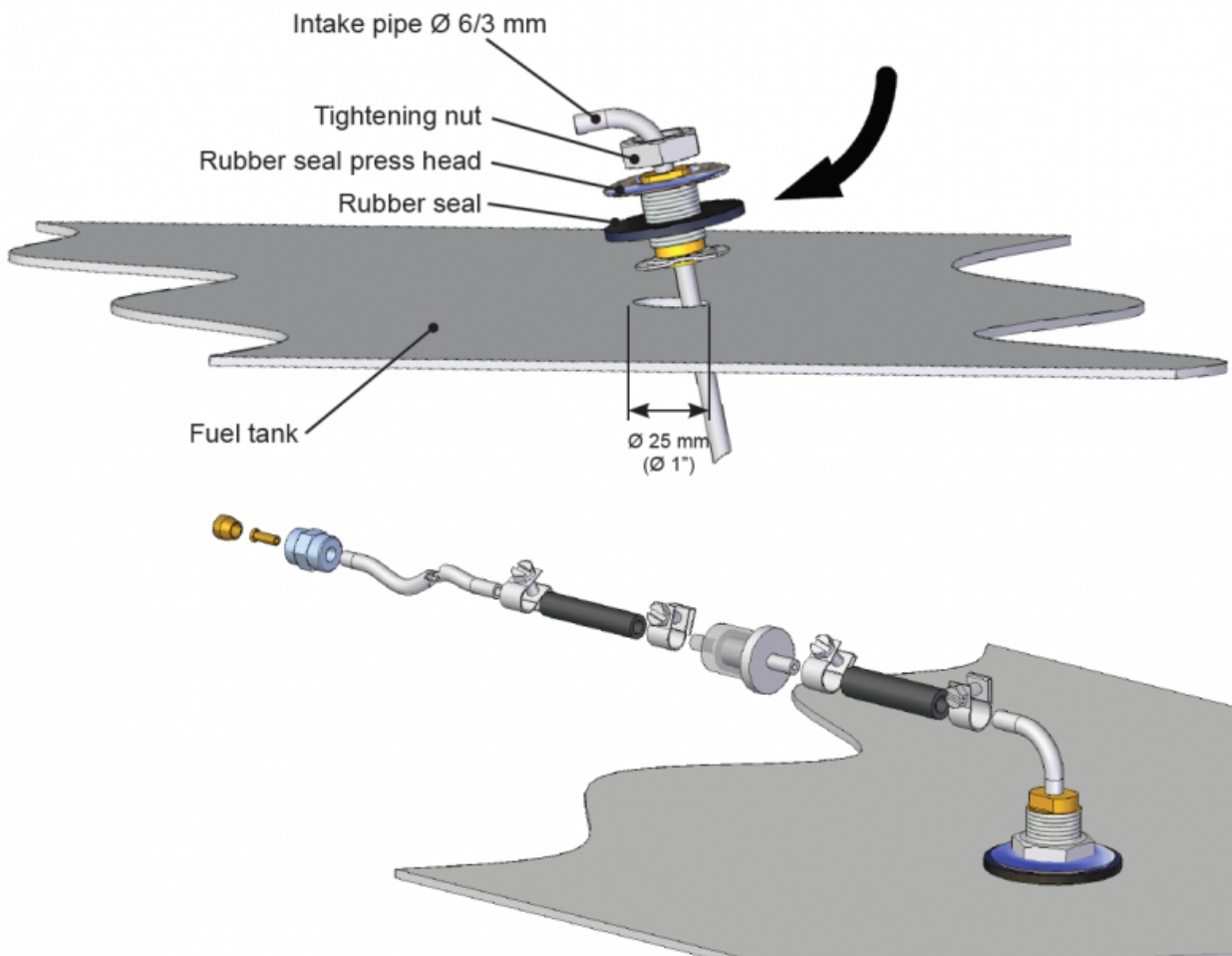

Installation instructions for Tank connection 30011

- You will need to make a \varnothing 25 mm (1") hole in the upper surface of the fuel tank. Choose the location of the hole so that when the fuel tank tilts the end of the intake pipe will stay in the fuel even if the tank is not full. If the end of the intake pipe does not reach the fuel, the device will quickly choke on the air in the fuel system.
- Cut the fuel intake pipe (\varnothing 3.17/0.8 mm) to the appropriate length. The end of the pipe must not touch the bottom of the tank in order to keep water and sediment from the system. It is recommended to cut the pipe short enough to leave the engine intake pipe at a lower level. This way the device cannot empty the tank.
- Install the pipe straight end first and angle the two "ears" below the threaded barrel inside the hole and then align the threaded barrel vertically so the ears are hooked on the underside of the tank top. Carefully slip the rubber washer over the bent pipe end and over the threaded barrel, followed by the metal washer and the nut. Thread the nut to the threaded barrel and tighten, sealing the fitting to the top surface of the tank.

Selecting the fuel

When selecting the fuel type, take note of the temperature limits of each particular fuel. The limit values provided here are to be treated as guidelines. Confirm the actual temperature limits from the fuel supplier.

- HVO-Diesel, Diesel, summer grade, temperature must not fall below -5 °C.
- HVO-Diesel, Diesel, winter grade, temperature must not fall below -24 °C.
- Diesel, arctic winter grade, temperature must not fall below -40 °C.

If the temperature drops lower than the minimum level, paraffin may form in the fuel. This may result in the fuel filter and pump being clogged. The clog will dissolve only if the fuel temperature rises clearly over 0 °C. The less aromatic substances the fuel contains, the less deposits will be formed.

Normal furnace oils contain 35-40 % of aromatic substances. In city diesels and green furnace oils (green diesel heating oil) the concentration is 20 %.

Installation instructions for separate tank connection

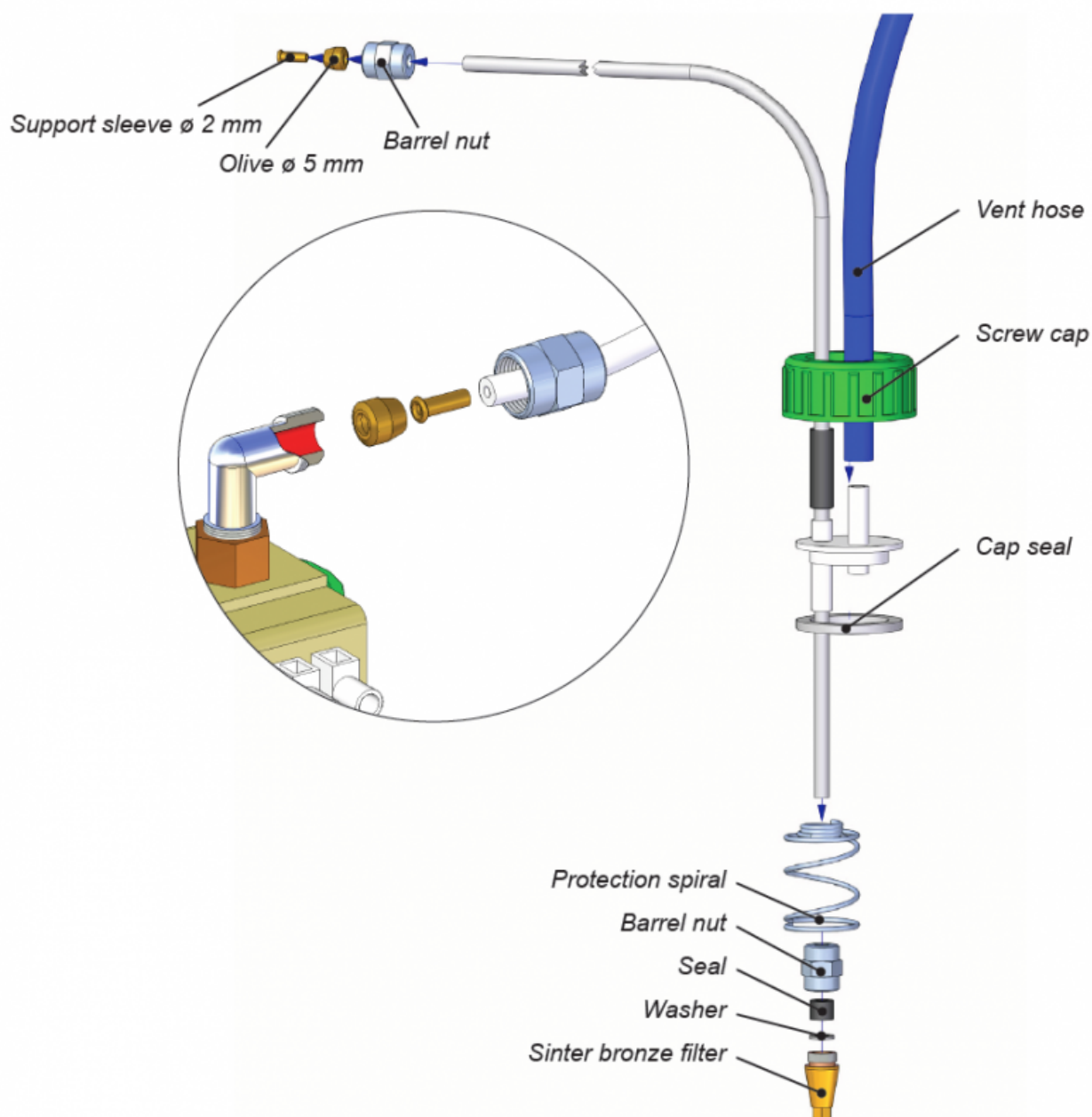

If the fuel will be taken from a separate Wallas day tank, you must install a tank connection 367215 (4 m) / 367216 (6 m).

- Tighten the barrel nut tightly to the fuel pump connector at the device end of the fuel system. Keep the parts and the hose clean and ensure that the connection is tight, because an air leak in the connector will stop the device from functioning.
- Install the tank connection in the tank.
- The joint has to be very tight to prevent air leaks. Tightening torque is 19Nm.

Tank external filters

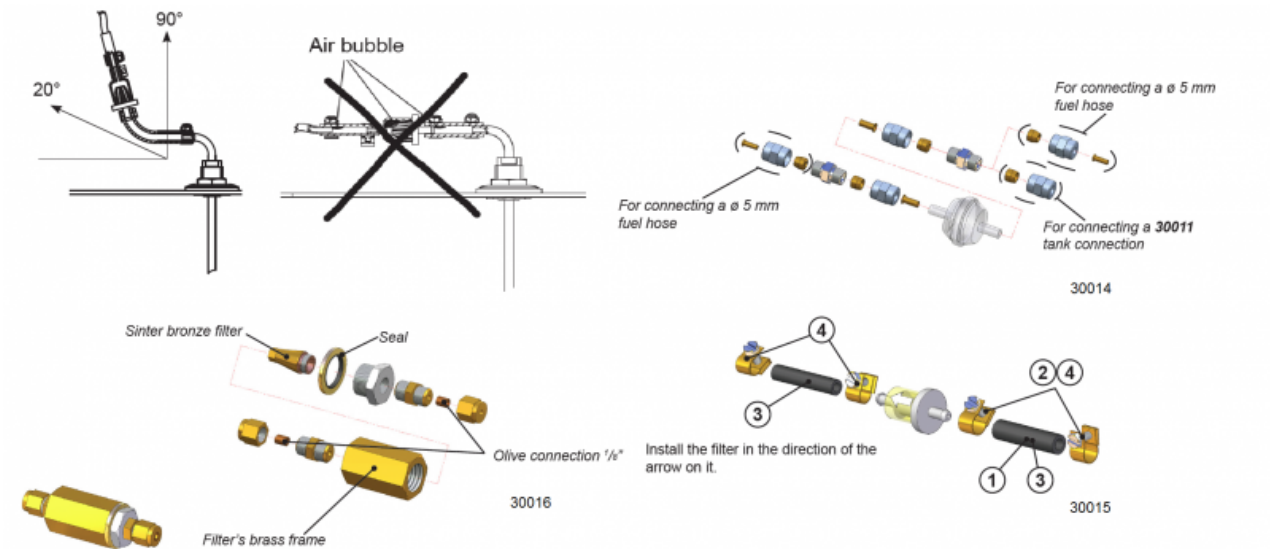

Filters can be installed in a $\varnothing 5$ or $\varnothing 6$ mm plastic tubing or 1/8" metal pipe. Ensure that the fuel pipes are clean before installing the filter. There must be no debris or impurities between the pump and the filter as they will clog the pump. The filter type must be selected according to the operating conditions and country-specific requirements.

Fuel filter 30015

The filter can be installed directly in the 30011 tank connection by using a $\varnothing 6$ mm rubber hose (1) and 10 mm hose binders (2). Alternatively, the filter can be installed between two $\varnothing 5$ mm fuel hoses with $\varnothing 5$ mm rubber hose (3) and $\varnothing 8$ mm hose binders (4).

Fuel filter 30014

This filter is intended for cold conditions.

The filter can be installed directly in the 30011 tank connection by using a $\varnothing 6$ mm barrel nut and 6 mm olive. Alternatively, the filter can be installed between two $\varnothing 5$ mm fuel hoses with $\varnothing 5$ mm barrel nut, $\varnothing 5$ mm olive and $\varnothing 2$ mm support sleeve.

Fuel filter 30016

Used in countries where a metallic fuel transfer system is required. A 1/8" metal pipe is used for the installation.

Solenoid valve

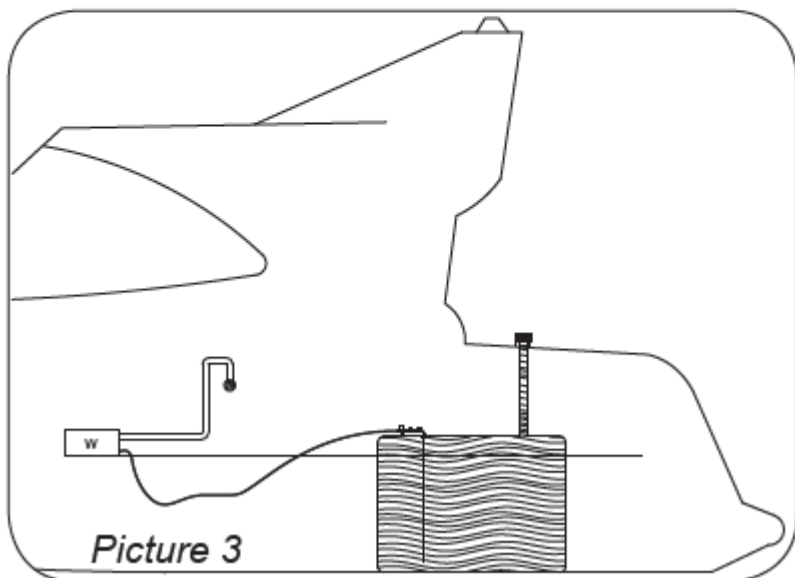
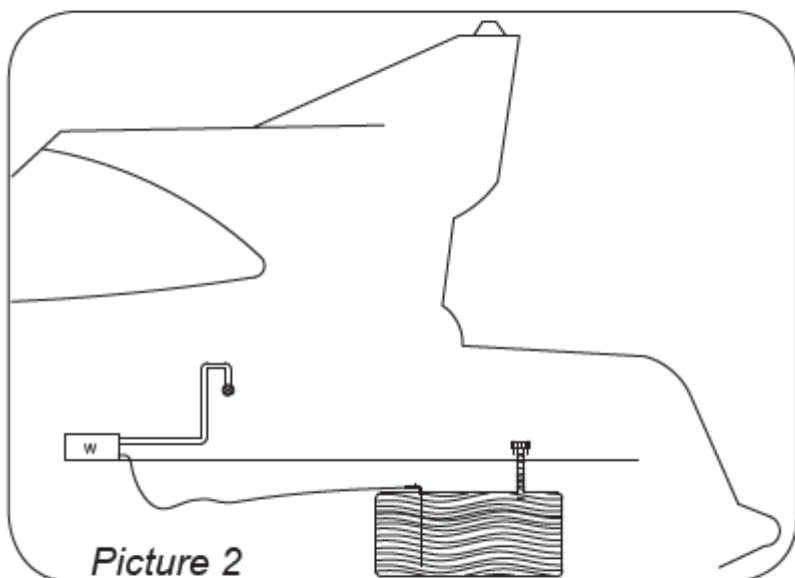
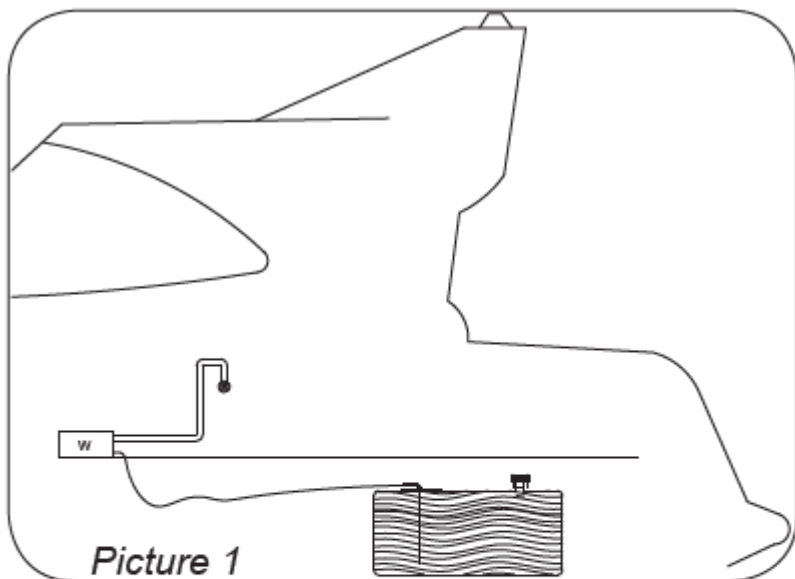

The solenoid valve 30012 prevents the tank from emptying in case the fuel line breaks. The fuel filter should be installed before the solenoid valve.

Our recommendations in the following installation scenarios:

1. Fuel level is below the heater/stove. Picture 1.

- Recommended installation scenario
- No special accessories required

2. Fuel level may temporarily rise above the heater/stove (e.g. in the fuel tank filler pipe or when the boat tilts). Picture 2.

- No special accessories required

3. Fuel level is above the heater/stove. Picture 3.

- Non-recommended installation scenario
- Possible siphon problem
- Solenoid valve 30012 must be installed in the fuel hose near the tank.

Exhaust gas connections coaxial

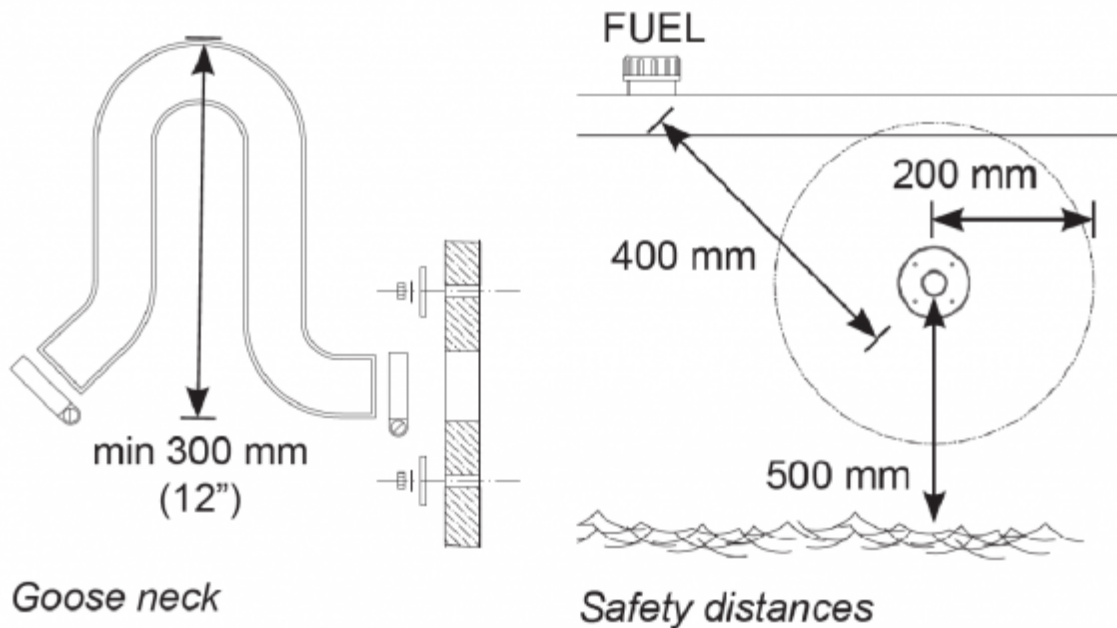

Exhaust gas lead-throughs

Exhaust gas lead-throughs **2467**, **5400** and the closable model **2460** are suitable for Wallas unit. The \varnothing 28/45 mm lead-throughs fit the exhaust gas hose **2448**, providing maximum wind tolerance.

Optionally, the Wallas unit can be run using singular exhaust hose **1028** with **1030** insulation sock and the **1066** exhaust lead-through.

All exhaust gas lead-throughs are stainless steel.

General instructions for exhaust gas connections

LOCATION

Air must always flow freely past the lead-through. Install the lead-through on a flat surface. Avoid corners or recessions where wind pressure can disturb the functioning of the device.

The minimum distance of the lead-through from the fuel tanks filler hole is 400 mm (16").

The minimum distance of the side lead-through from the surface of the water is 500 mm (20"). Especially in sailboats it should be noted that the lead-through must never be submerged for more than 5 seconds.

It is recommended to place the lead-through in the side as far back as possible or directly in the transom.

INSTALLATION

When preparing the installation cut-out for the lead-through, it is a good idea to use the lead-through as a model for the cut-out. Seal the installation cut-out with silicone in addition to the leadthrough seal. Note! Do not use silicone on a wooden boat. The side lead-through must always be equipped with a "goose neck" section. The goose neck will effectively prevent splash water from getting to the device. The highest point of the goose neck must always be above the surface of the water. The device will go out, if the exhaust gas lead through is submerged for more than 5 seconds.

OTHER THINGS TO NOTE

Exhaust gas is hot. Always ensure that there is nothing that is susceptible to heat damage within 200 mm (8") of the effective area of the exhaust gases (e.g. ropes, fenders or the side of another boat). All lead-through's raise the temperature of their surroundings. A wooden deck, in particular, may dry due to the heat. Remember that the surface of the lead-through is hot during use.

Singular exhaust hose 1028 with a length of more than 2 meters (7') has to be equipped with a drainage lock 602293 (condense water) located to the lowest point of the tube. With coaxial exhaust hose 2045 drill app. 2 mm (3/32") hole to the lead-through or to the exhaust pipe to get the water out.

The Exhaust gas pipe must be made of stainless steel. If necessary, seal the connections between the exhaust gas pipe and the lead-through with heat-resistant silicone. When installing the lead-through to the stern side or to otherwise leaning position, be sure that the water do not stuck the exhaust.

Side lead-through 2467

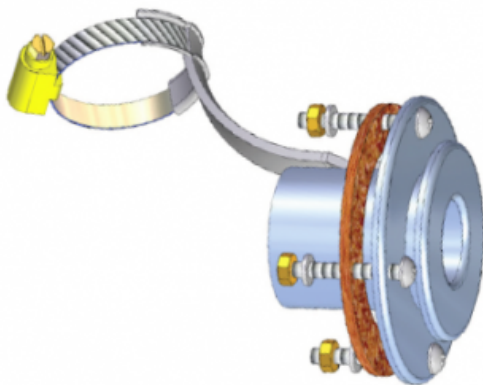

2467 Side lead-through

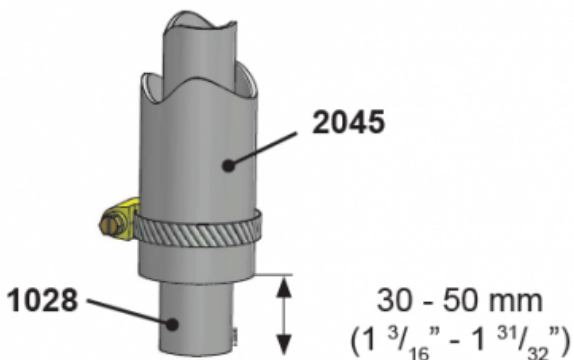

Length difference of the pipes

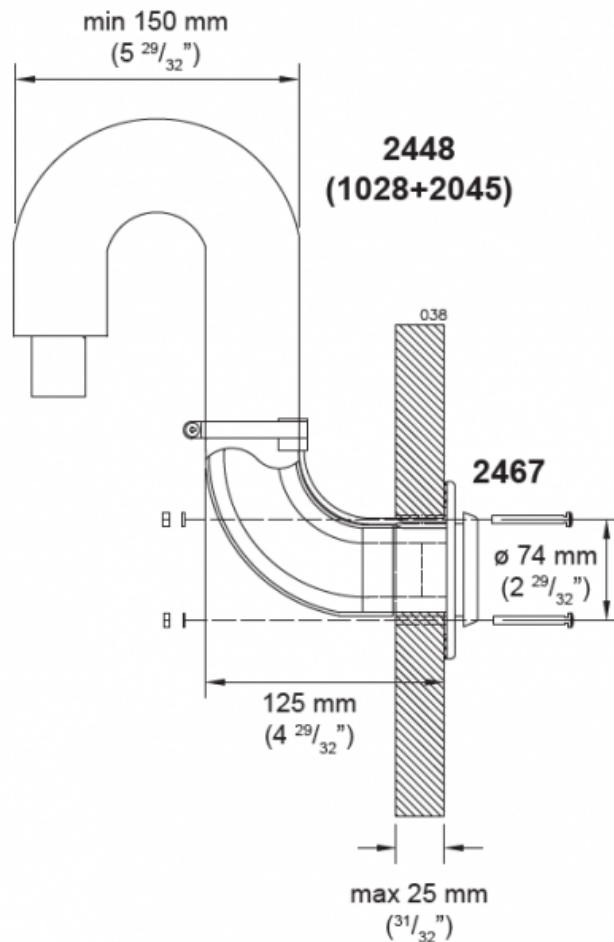

Side lead-through 2467 installed.
The installation cut-out is $\varnothing 50$ mm ($1 \frac{31}{32}$ ") and the screw holes are $4 \times \varnothing 6$ mm.

A side lead-through is installed in the side of the boat or in the transom. In sailboats it is recommended to install it in the transom. The installation always requires a so-called goose neck piece. Make the necessary installation cut-outs and spread a suitable sealing agent on both sides of the seal and on the screw holes. This will ensure that the connection is waterproof.

The 1028 exhaust gas pipe must be 30-50 mm ($1 \frac{3}{16}$ " - $1 \frac{31}{32}$ ") longer than the 2045 inlet pipe. This way the exhaust gas pipe will stay in place in the lead-through more firmly. The measurement depends on the overall length of the piping.

Package contents

2467		
1 pcs	Side lead-through	

1 pcs	Accessory bag 17679	
	4 pcs	Fastening screw M5 x 40 mm
	4 pcs	Nut M5
	4 pcs	Washer 5,3 x 10 mm
	1 pcs	Hose clamp 32 - 50 mm
	1 pcs	Gasket

Closable lead-through 2460

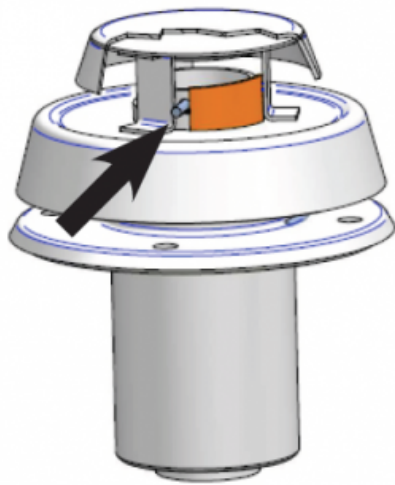

2460
Closable lead-through.

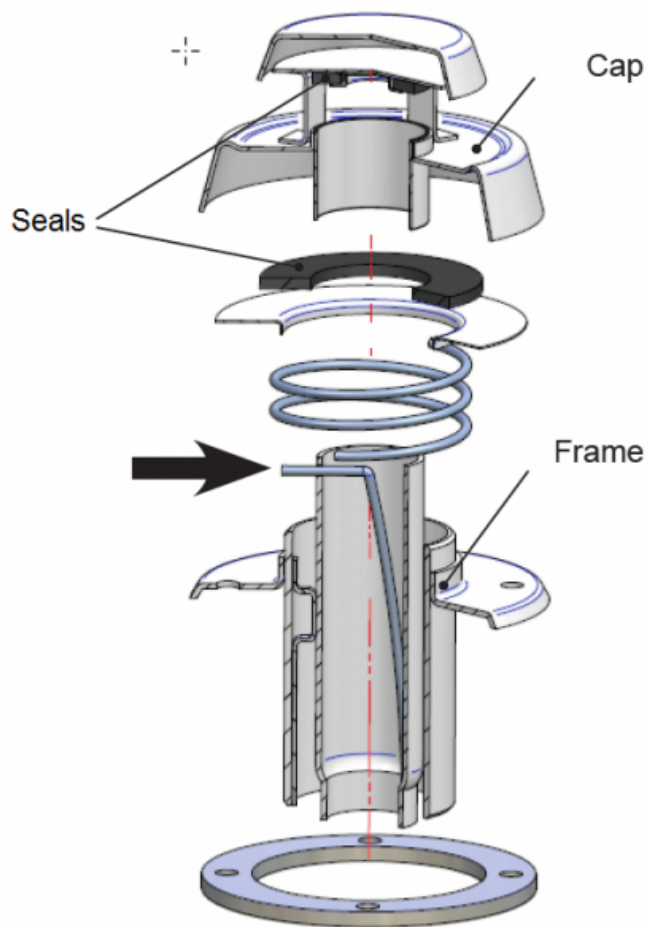

The cap of the closable lead-through must be detached for installation and seal maintenance by pressing the spring indicated by the arrow in with, for instance, a screwdriver. Take care not to let the screwdriver slip as the spring is very stiff. Hold the cap with your other hand when pressing in the spring. When the spring is down, pull the cap gently out of the frame. When assembling the lead-through, ensure that the order of the parts is correct. Also make sure that the spring goes in the correct hole in the cap. Otherwise, the lead-through cannot be closed.

Maintenance

To keep the seals from hardening, lubricate them yearly with a heat-resistant petroleum jelly.

Check that closeable fitting is open before starting the device.

2460		
1 pcs	Closable lead-through	

1 pcs	Accessory bag 17676	
	4 pcs	Fastening screw M5 x 85 mm
	8 pcs	Nut M5
	4 pcs	Washer 5,3 x 15 mm
	4 pcs	Washer 5,3 x 10 mm
	1 pcs	Hose binder 32 - 50 mm
	1 pcs	Gasket

Stern lead-through 5400



Exhaust lead through for negative transom. Designed especially for sail boat's stern.

Insulation kit

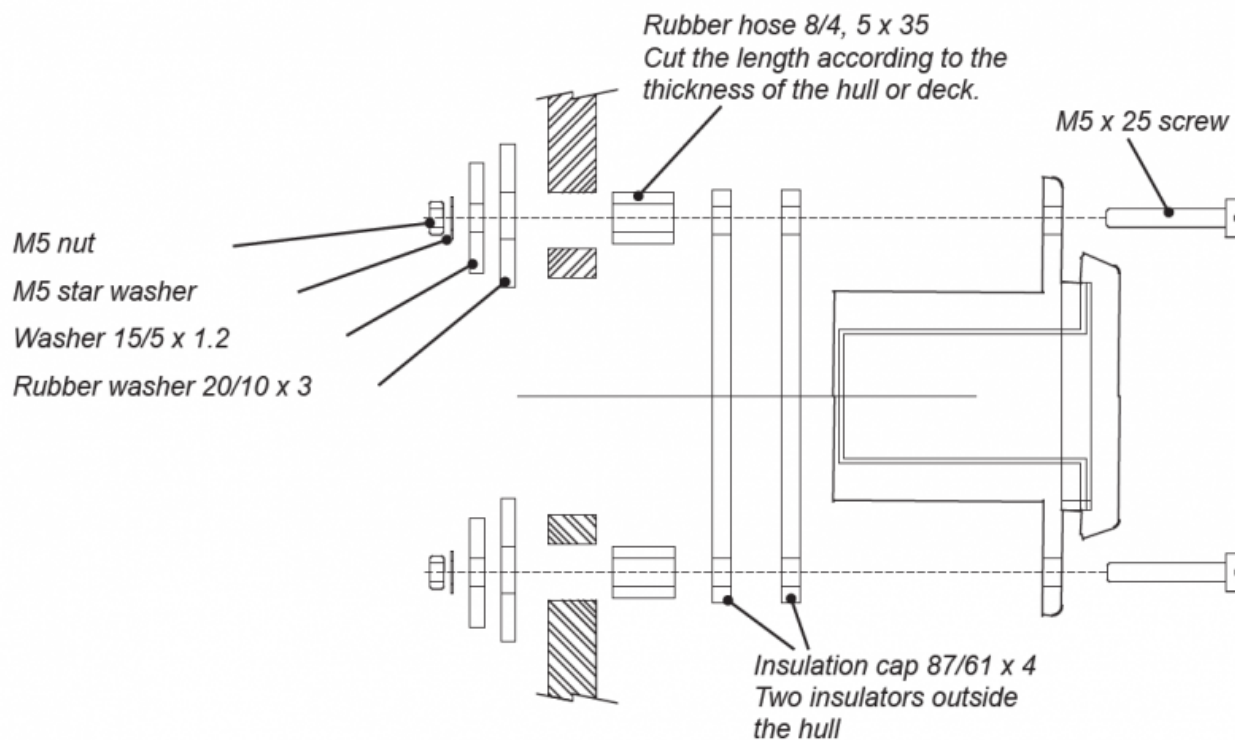

Insulation kit for a metal-hulled boat

An insulation kit must be used to insulate the lead-through from the boats metal hull. The insulation kit insulates the exhaust gas lead-through and the device from each other. In fault situations the electric circuit runs between the metal hull and the device. This can result in the oxidation or malfunctioning of the devices circuit board, the circuit board may be damaged.

Insulation kit 2461 for circular coaxial lead-throughs.

Functions

Ignition

The start-up process and heating is automatic. The heater will ignite when the heating is turned on. Operation panel states "starting". A yellow combustion indicator light will be lit when the burner flame has been ignited and the combustion has stabilised after about five minutes after the ignition. The whole process takes about 11 minutes

First start-up

After installation or maintenance, if the fuel line is empty, the heater may not start at the the first attempt. Start-up phase with empty fuel line is longer than normally and might take about 15 minutes. If the heater doesn't ignite the red combustion indicator light will start to blink after start-up. Turn off the heater. The device cannot be restarted until the cooling phase is completed. When the cooling phase is finished, switch the heater on again. If the device does not start after two attempts, it cannot be started again: the heater will lock itself (lights blink to indicate this). Find out the reason why the unit didn't start. If the heater iginites during two attempts the yellow combustion indicator will go on. After locating the fault, release the locking through operation panels menu and start-up the unit. Depending on the length of the fuel hose, the heater may have to be started up several times during priming. Keep an eye on how the fuel travels in the fuel hose while starting up the heater.

Adjusting the heat

Adjustment of temperature can be done by using thermostat (recommended use) or manually. The desired mode is chosen by selecting wanted function from the operation panel.

Thermostat mode

Thermostat mode is selected from operation panel and unit takes care of wanted temperature. Temperature can be adjusted between 5-35C°.

Manual use

The power can be adjusted manually by selecting manual control from the operation panel. Power can be adjusted levels between 1-6. 1 illustrates minimum possible burner power, 6 illustrates maximum power.

Air boost

The air boost is meant to be used when you need higher air volume, for example to remove moisture. When the heater is running, the air boost can be activated by selecting the ventilation icon and pressing it on by button. The heating continues according the set effect, but the air volume increases to maximum effect. The air boost is indicated by the orange air boost icon.

Ventilation

Fresh air ventilation can be activated by selecting the ventilation icon from the top line, and then selecting the power icon and with long press. The yellow power icon indicates that ventilation is on, and there are no access to heating mode when ventilation is on. Ventilation is deactivated by long press of the power icon. The The yellow power icon will disappear. The ventilation can be adjusted smoothly between levels 1-6.

Note ! when adjusting the ventilation effect the change of rotation speed of the ventilation motor will take place slowly after the knob is turned.

Shutdown

You can shut down the heater by selecting the power icon and pressing it long. The yellow heating indicator light will go out immediately. The yellow combustion indicator light will continue to blink for about five minutes, while the device is cooling down. You cannot restart the device until the combustion light has stopped blinking.

Controlling the device

Operation panel is controlled with rotary switch and selection button. Rotary switch can be used turning frame right or left. Button is integrated to panel and is used by pressing upper face of panel.

First time start up

When connecting power first time, the panel opens a tutorial for operations. Options are start heating, start ventilation or menu. To move in menu use rotary switch, select function by long press of button.



Adjust wanted temperature by rotary switch and accept that with button

When temperature is selected and accepted, panel goes to operation screen.

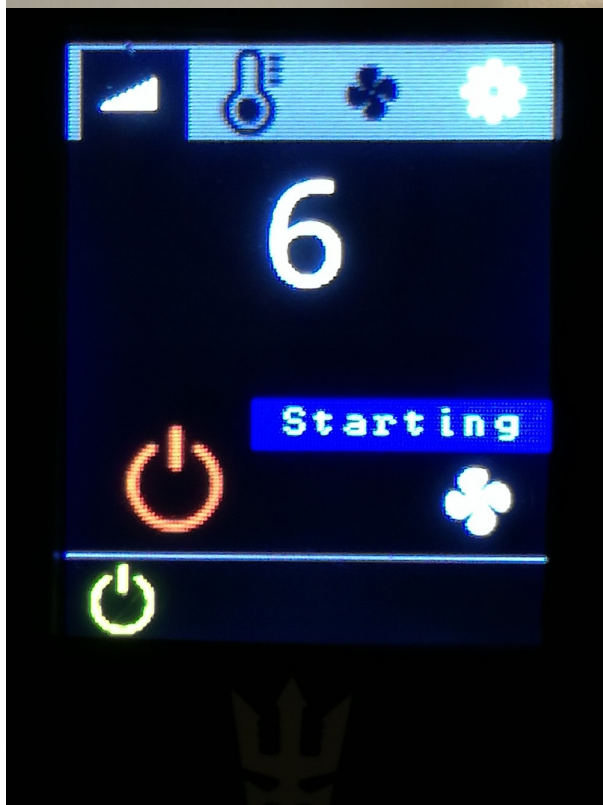
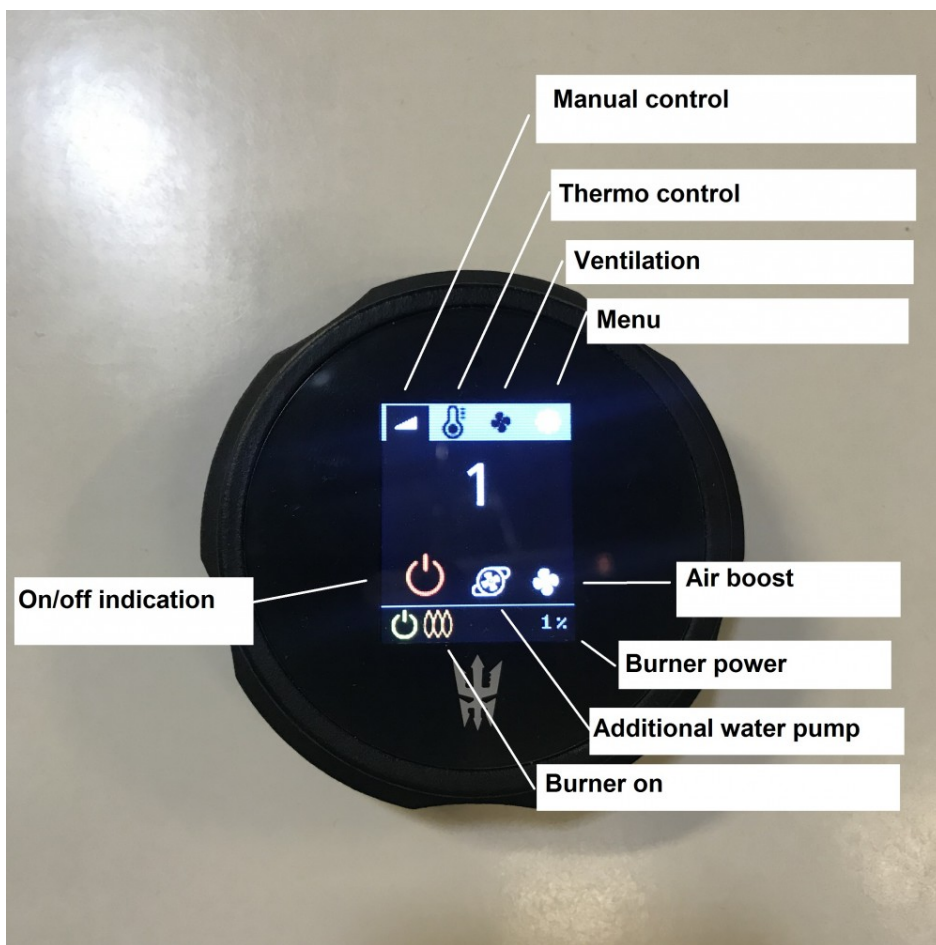



When burner ignites, the flame indicator light is turned on.



When starting protocol is completed mode indicator "starting" turns off. Selected function is highlighted. When something needs adjustment, select wanted function by turning rotary switch, push button and do wanted changes by rotary switch. Accept changes pushing the button.





Turning on the additional water pump. This function controls the relay left on the units circuit board, and is designed to be used for additional water pump for circulating water through heated seats, mats or other possible water circulations.



Air boost

The air boost is meant to be used when you need higher air volume, for example to remove moisture.



Manual control

On manual control the heating power can be adjusted between 1-6.



Heater is turned off by selecting power indicator and long press of button.







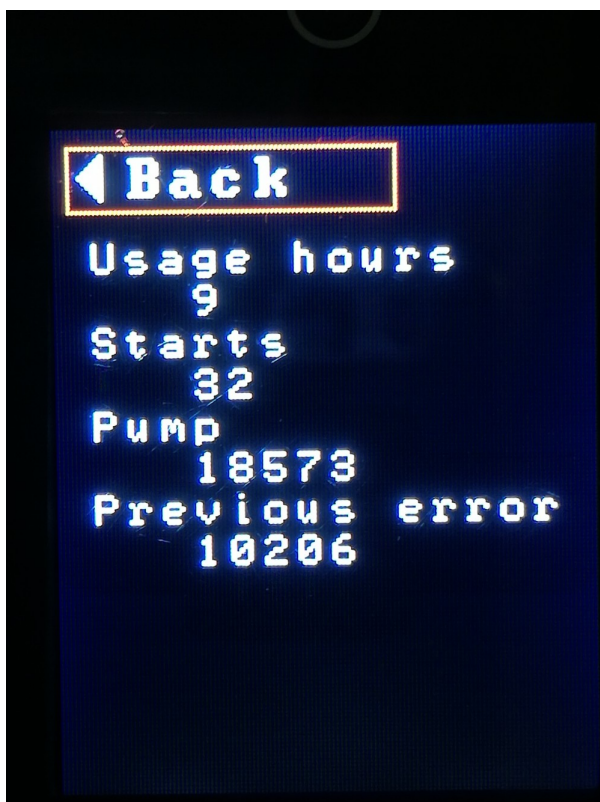



Check list

Installation

- Ensure sufficient air ventilation for heater, minimum aperture of 100 cm² (16 sq. in.) into installation area.
- Ensure that the boat is sufficiently ventilated.
- The exhaust pipe outlet must be at least 400 mm (16") away from the opening for filling fuel or tank breather.
- We recommend installing the operating panel on a vertical surface where liquids are not able to leak into the switch and it is out of reach of children (cable length 6 m).
- Installation carried by capable or trained person

Fuel system

- Fuel for the device comes through a separate tank fitting, not via a manifold or connection shared by the engine or other device.
- Install the filter to the fuel hose before you install the device, in an accessible location for filter changes.
- Fasten the fuel hose couplings tightly. Always use a sleeve joint on the hose (olive ring).
- Make sure that the surfaces of the couplings are clean before fastening them.
- The hoses must be kept clean during installation.
- Use only Wallas fuel hoses.
- If the surface of the fuel tank is above the device, a magnetic valve must be installed into the fuel hose close to the tank.
- Cut the fuel hoses to the appropriate length when installing them.

Electrical installation

- The nominal voltage of the device is 12 VDC.
- Current for the device is taken directly from the battery terminals using cables that are as short as possible.
- Put the main fuse of c. 15 A on the + cable close to the battery

Exhaust fumes

- When choosing the outlet location, note that exhaust fumes are hot.
- Use a goose-neck to prevent splash water entering the boat from splashing into the outlet.
- If your boat has a metal hull, the device and

outlet must be insulated from the hull to prevent electrochemical corrosion.

- The exhaust pipe must not come into contact with combustible materials. Insulate the exhaust hose if necessary.

Warm air

- ø 90 mm air hose is not allowed to reduce. It is allowed to divide 90mm hose to two 75mm hoses.
- It is recommend to insulate the warm air hoses.
- Note! Warm air registers are not allowed to be closed at the same time.

Warm coolant hosing

- Flow direction is correct
- All hoses are rising from the lowest point to higher
- There is no leakages in the system
- Header tank is large enough
- System contains enough coolant to prevent freezing
- System is bleed correctly
- Hoses are coolant resistant material

I confirm that the installation is done according to this manual.

Serial number	
Company	
Installer	
Installation date	
Signed	

Installer must check (x) the sections, then sign his/her signature.

Bleeding and filling coolant ducting

Its easiest to fill ducting starting from the lowest point of installation. **If you start filling from the header tank there will be airlocks.** Filling from the lowest point takes most of the air out from the system, so this makes bleeding much easier. If there is air in the ducting heater does not work correctly.

Premix enough coolant (30% antifreeze, 70% water)

1) Install T-branch to the lowest point of coolant ducting

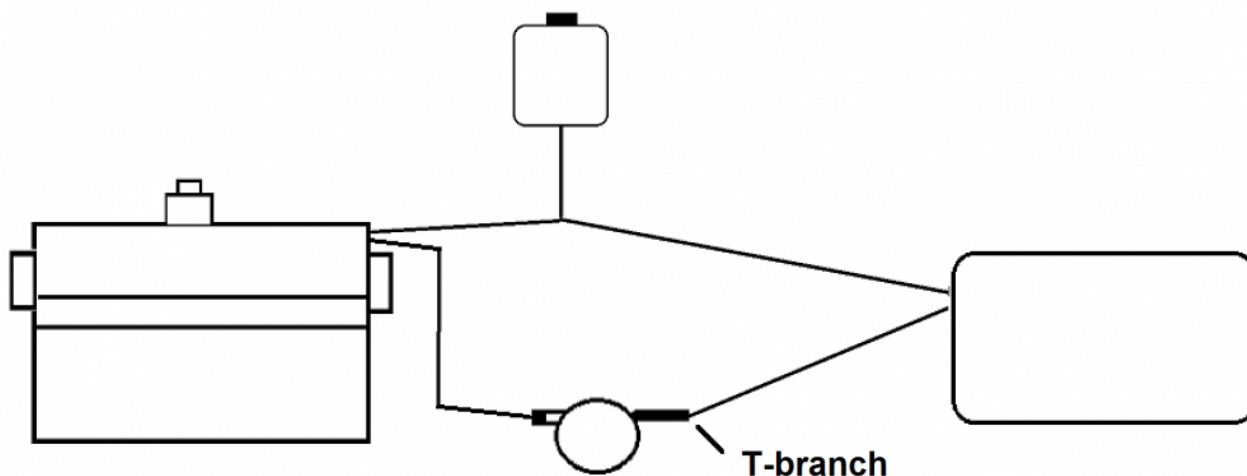

2) Connect drill pump to the free end of t-branch and close one line with hose pinching pliers.



3) Pump coolant through the drill pump until header tank starts filling.

4) Relocate pinching pliers to the another line and start pumping coolant until it reaches the header tank.



5) Unplug the drill pump's hose and plug T-branch.

First time start up procedure

System overview

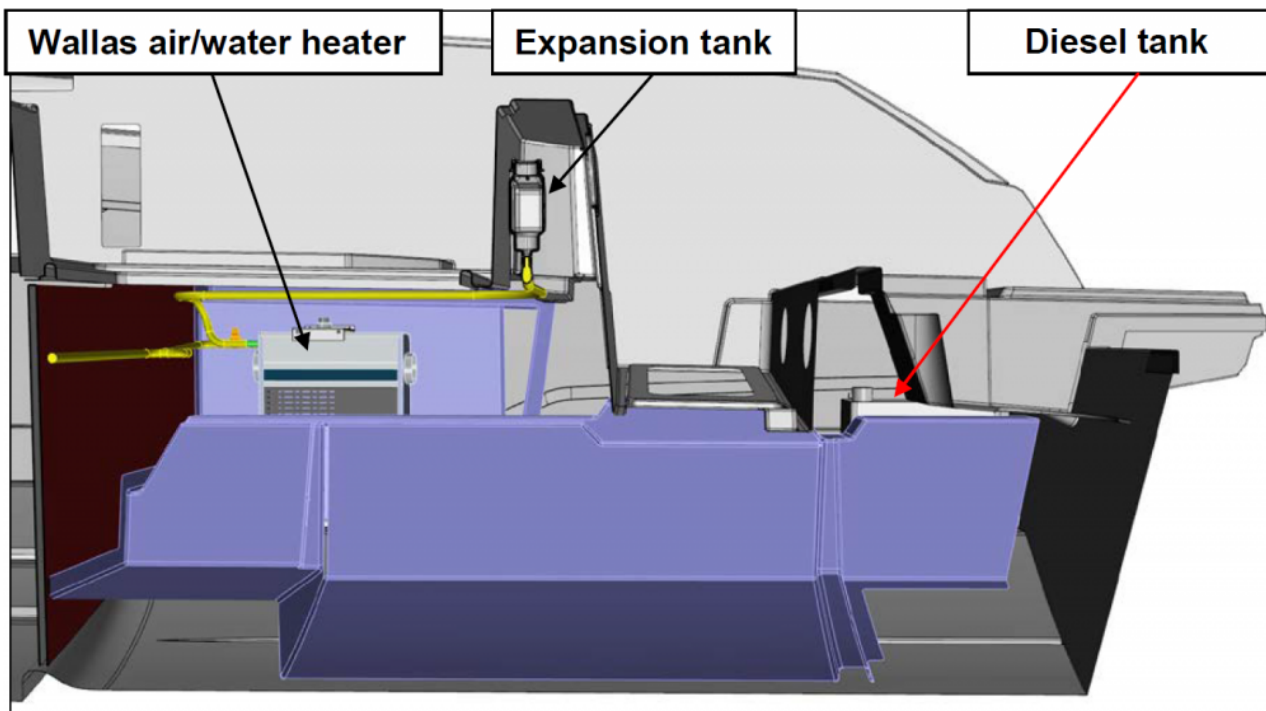
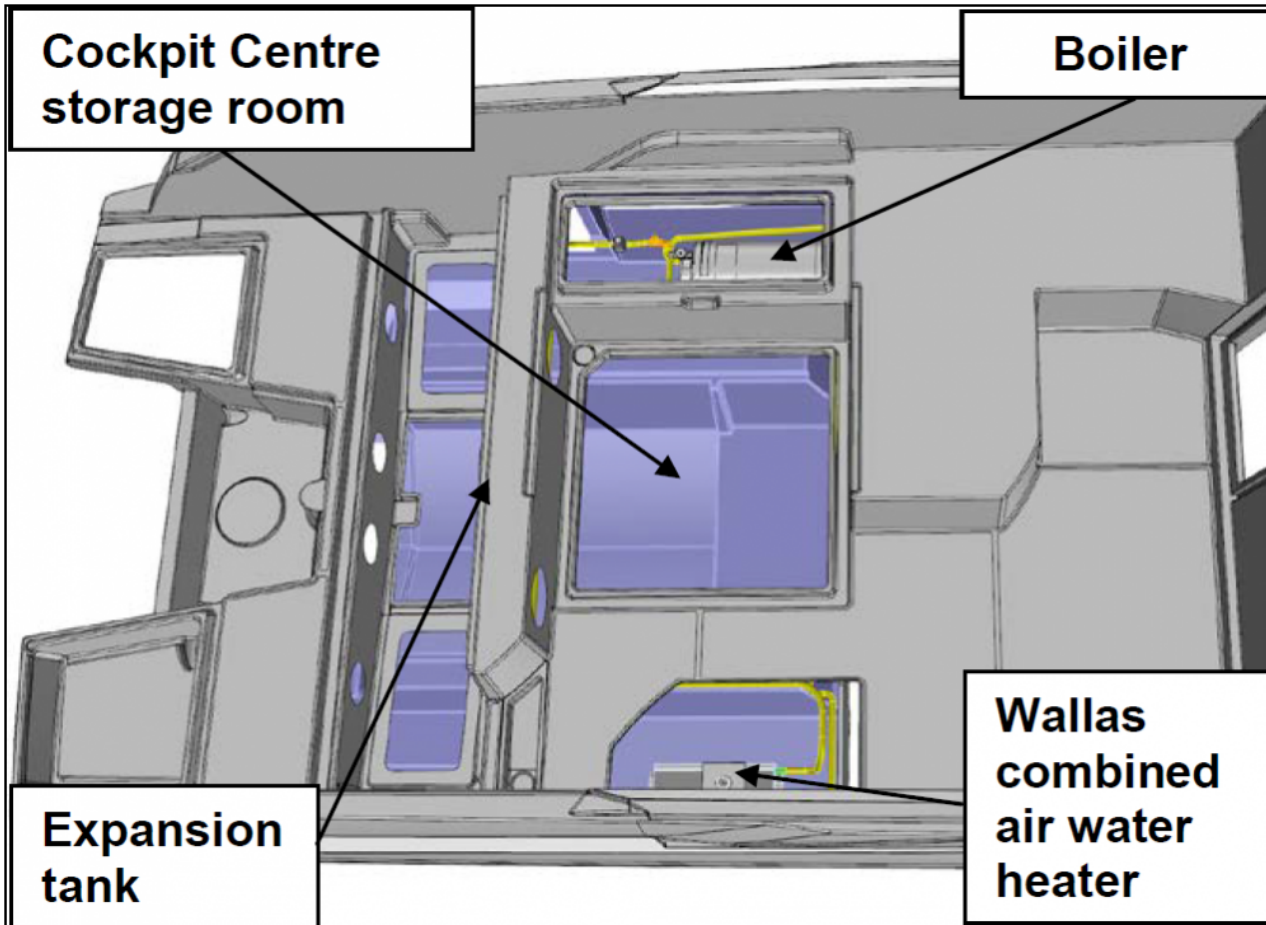

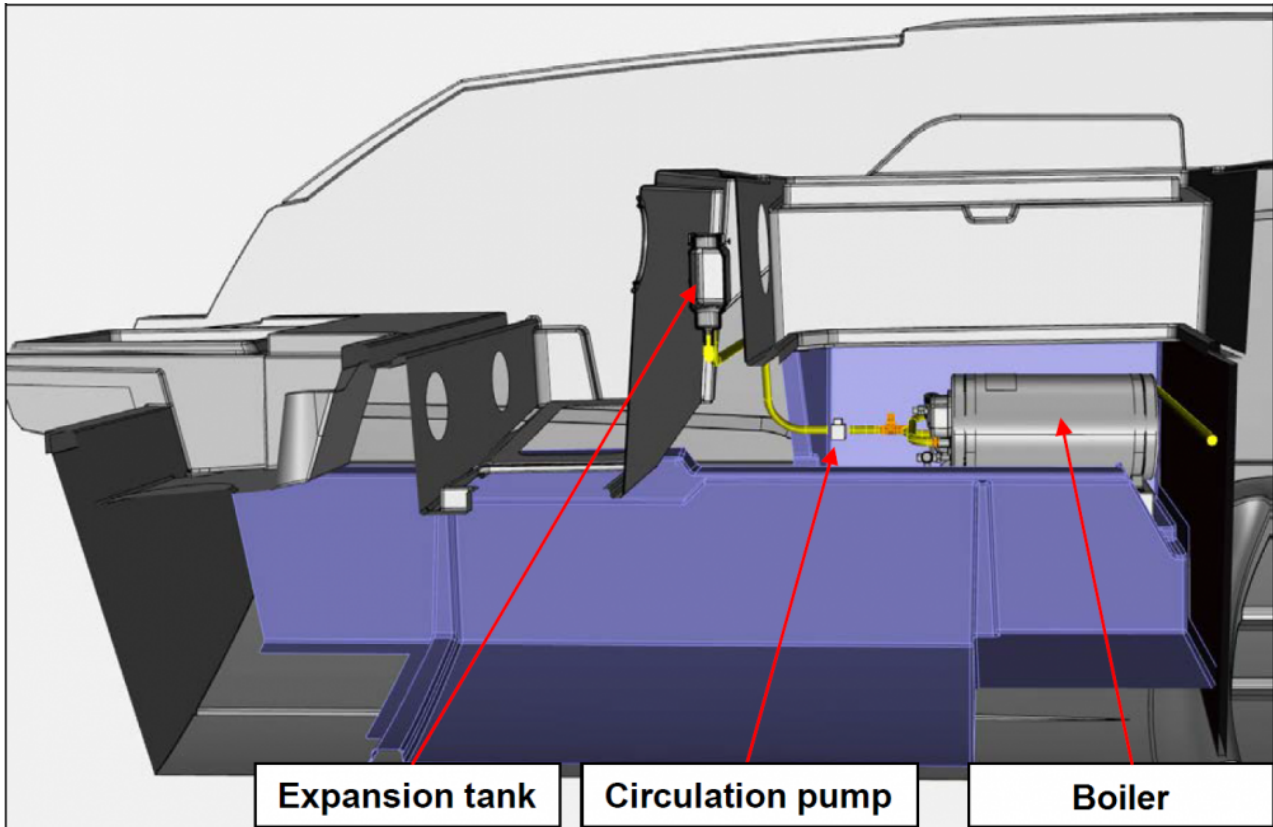

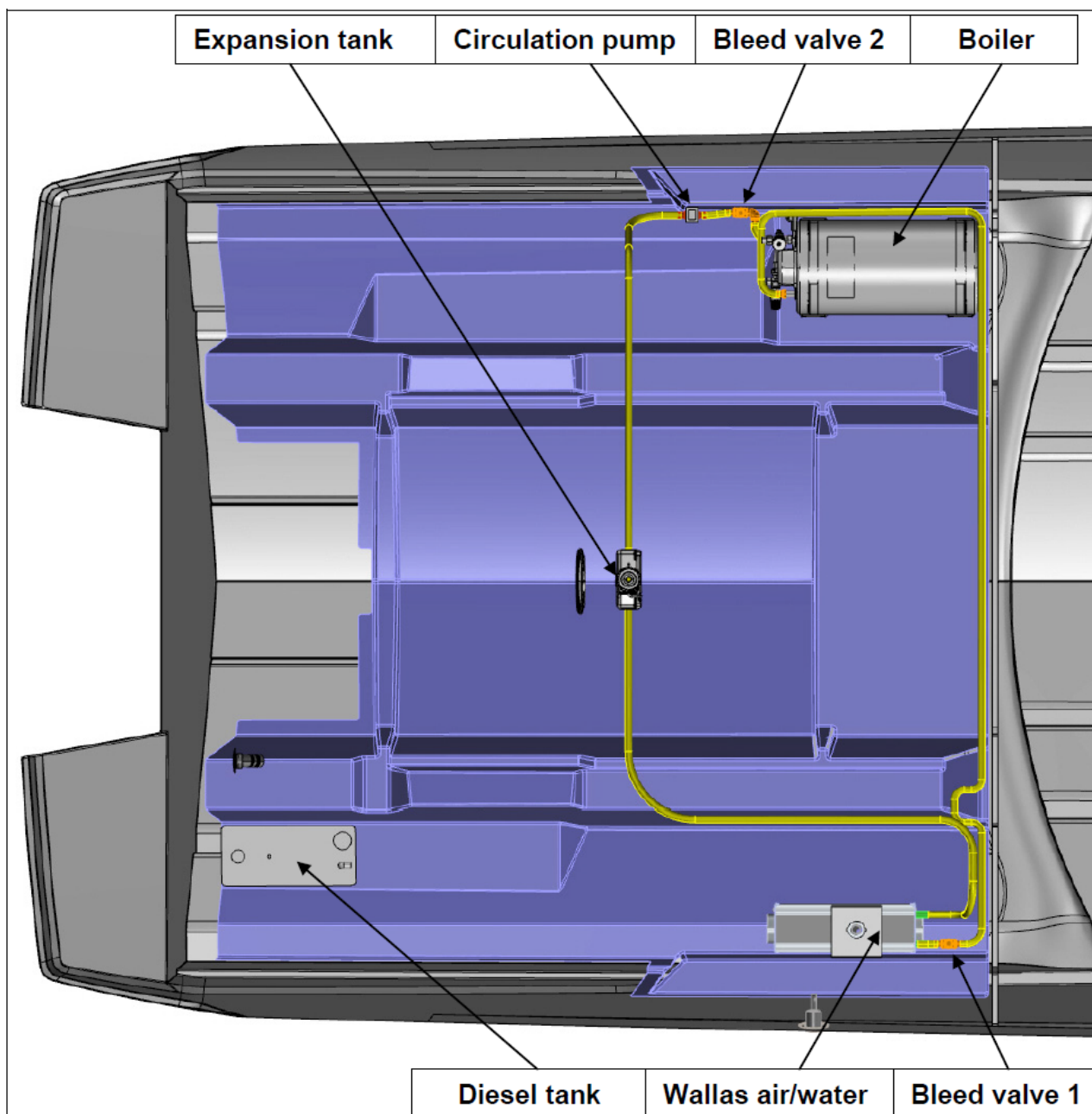

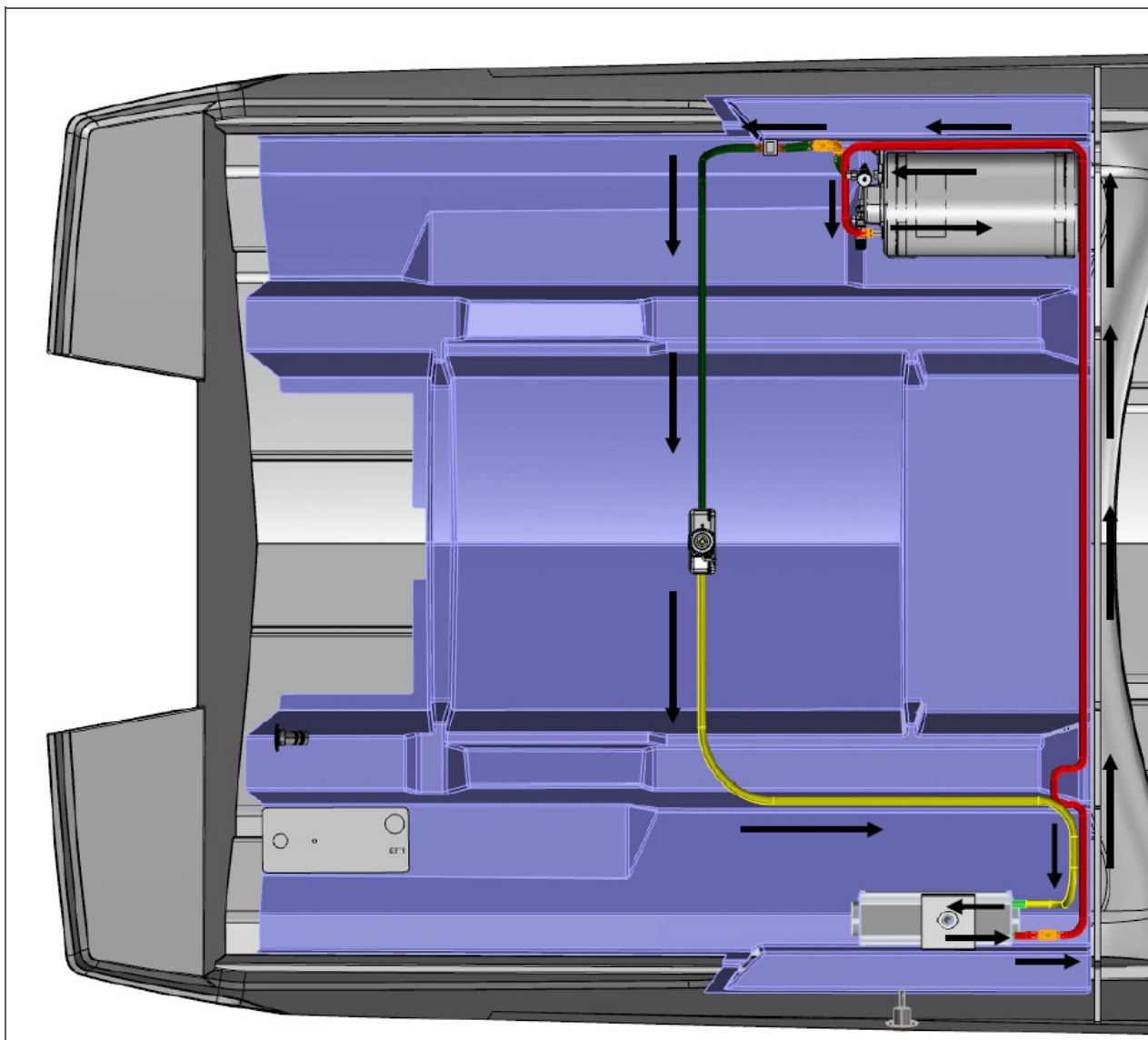

Inspection of the system before bleeding air and first start up

- 1) Fill the fresh and the hot water tank. Do not have the circuit breaker for the hot water tank on, boiler must be cold.
- 2) Check the coolant hose routing

It is important that the hose from expansion have a free drop down to the Wallas heater.

Approved routing of hose from header tank to heater

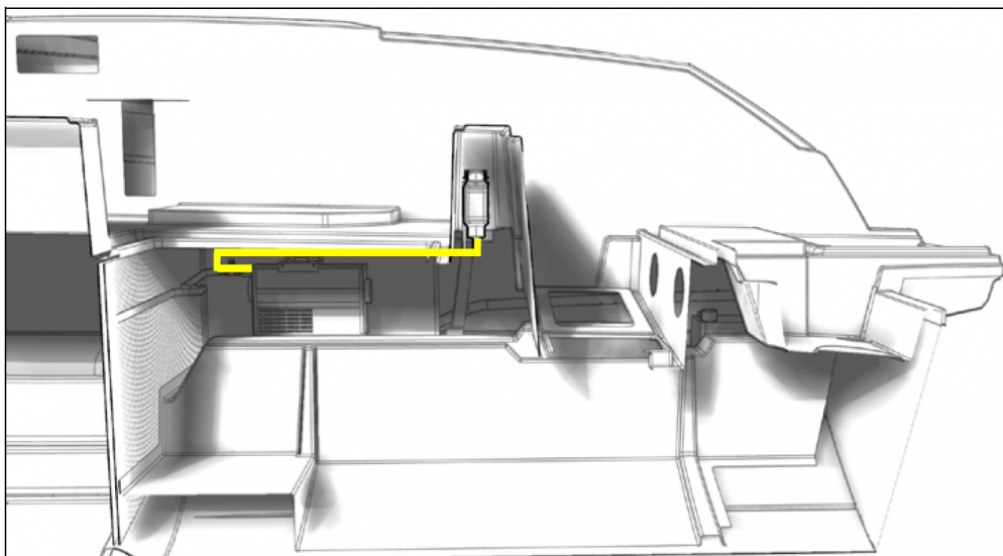

Not approved routing

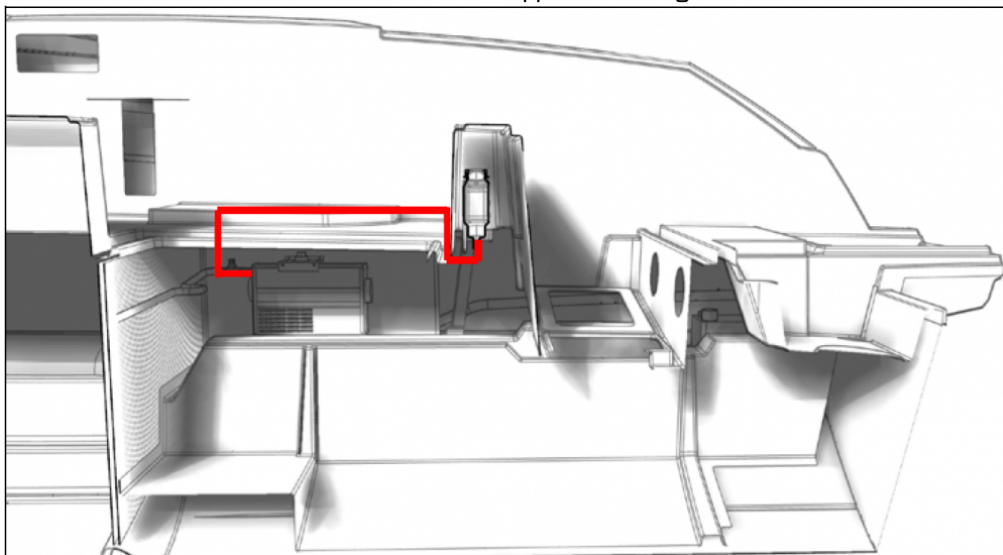

Not approved routing

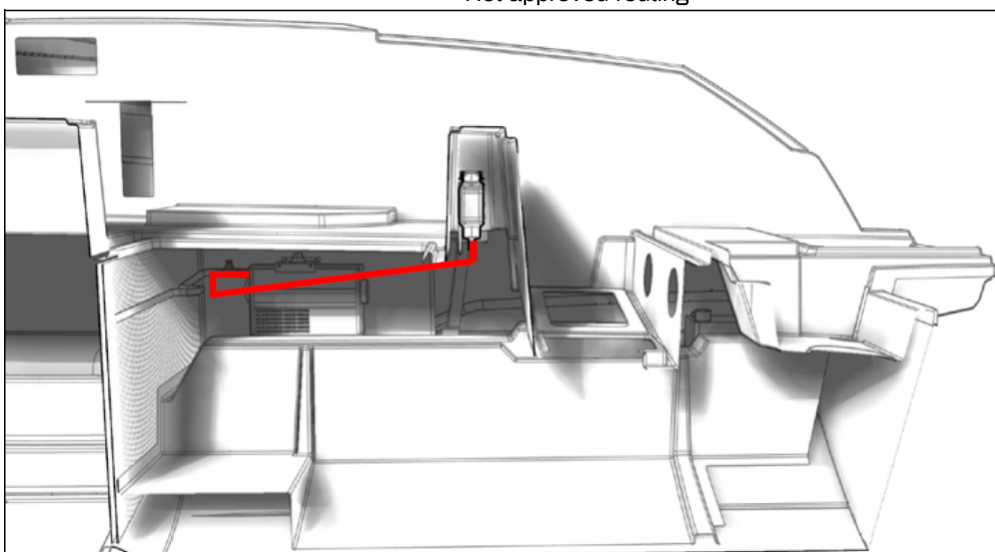

3) Make sure that all bleed valves are in locked position.

4) Make sure that header tank is still full

5) If not, fill the header tank to the max mark

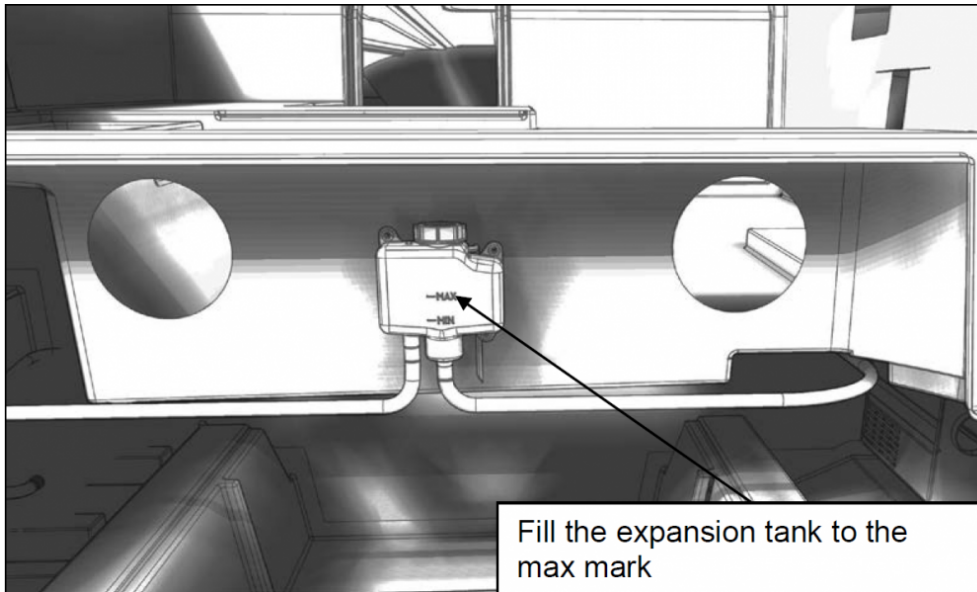

6) Open bleed valve no.1

Warning: Do not start the heater

Keep the bleed open until the flow of coolant is smooth and without air bubble's. You may need to fill the expansion tank at the same time to prevent the expansion tank to run empty of coolant, before the air is aired out through the bleed valve.

Close the bleed valve when the coolant flow is constant and without air bubbles.

Repeat this for every bleed valve in the system. Start with nearest bleed valve from the header tank towards flow direction, and then follow the direction of the flow.

Close the bleed valve when the coolant flow is constant and without air bubbles.

7) Fill the header tank with coolant

8) Start the heater.

Make sure that there is enough fuel for running the heater for one hour. Check that fuel filter is filled and fuel is primed to the heater. If there is a leak in the fuel line, the fuel pump runs dry and the heater goes to lock mode because of failed start up.

9) When the heater is starting, start to top up the header tank. When the heater is running the circulation pump will start to pump the coolant around in the system.

Note: If the header tank runs out of coolant the system will be filled with air and the first steps of bleeding the system needs to be done again.

10) Make sure to have enough coolant in the header tank. Open bleed valve no. 1

Let the air out of the valve. Close valve when there is only coming coolant out.

Repeat this for every bleed valve in the system. Start with nearest bleed valve from the header tank towards flow direction, and then follow the direction of the flow.

Make sure that there is all the time enough coolant in the header tank.

11) Fill the expansion tank to the maximum mark and let the heater boil the hot water.

12) Make sure that the water is circulating in the expansion tank.

13) After running with the state "Open Flame" in the control panel for approx. 15 minutes the water hoses should start to become warm.

14) Do the inspection for installed accessory to make sure that everything works as supposed to. (Hot water taps, heated seats, etc)

15) Keep control on the coolant level in the header tank.

16) Check that heater is blowing hot through installed vents.

17) Let the system run for an hour, check for coolant leaks and check that the temperature off the hot water is rising up to set temperature. The temperature of the water should rise 6 C° during 1 hour with 10 l of coolant.

18) Turn the heater off.

19) Tight bleed valves properly.

20) Check that there are no heat damages.

Check for coolant leaks. Check the level of coolant in the header tank.

Check the battery voltage. It should not be lower than 12.5V. If battery voltage is lower than 12.5V charge the battery/ batteries.

21) Check the coolant level when the system is cooled down. If the level is under the max mark, top up the system to the max mark.

Maintenance recommendations

Maintenance procedure	Maintenance interval	Carried out by
First inspection of basic functions	Inspection after first 500 hours of use or the first season of use	Authorised Wallas service shop
Cleaning the burner	The service shop recommends a suitable maintenance interval after performing the inspection of basic functions.	Authorised Wallas service shop

Special recommendations

Occasional (monthly) use of the device will increase reliability by purging old fuel.

If the device uses the same tank as the engine:

Observe the engine manufacturers recommendation with regard to the fuel type and moisture removal.

If the device has a separate tank:

When selecting the fuel type, take note of the temperature limits of each particular fuel.

Winter storage

If the device uses the same tank as the engine:

- Change the fuel filter.
- Perform measures recommended by the boat/engine manufacturer to be performed before winter storage.

If the device has a separate tank:

- Drain the fuel tank in the autumn.
- Clean the tank and change the fuel filter.
- Fill the fuel tank with fresh and clean fuel in the spring.

For the device itself, you do not need to do anything.

Spare parts

Spare parts list, www.wallas.com

An anti-freezing agent for diesel vehicles may increase the forming of scale at the bottom of the burner and therefore shorten the maintenance interval.

Warranty terms

Wallas-Marin Oy (the manufacturer) shall be liable for any defects in the raw material or manufacture of the products and items sold by the importer for 2,000 operating hours or 24 months from the date of sale (whichever comes first) under the conditions noted below. Calendar term of the Warranty can be extended by an additional 12 months by registering the product in the website of Wallas-Marin Oy (www.wallas.fi) within three (3) months of the unit being sold to the end customer.

1. In the event of a defect:

- Look at the check list on the website or installation / usage manual (www.wallas.fi) to make sure the defect in question is not related to use. A simple problem might not be covered by the warranty water in diesel or unit requires a service.
- Notification of the defect must be given in writing immediately, if possible, but no later than two (2) months after the appearance of the defect. After the warranty period ends, a referral back to a notification at the time of the warranty period is not valid unless the notification was made in writing. A valid receipt or another reliable official document of the time of purchase is required for proof of warranty eligibility.
- For repairs under warranty, the customer must take the product to the place of purchase (the seller is responsible for handling units with warranty issues), to an authorized repair shop or to Wallas-Marin Oy factory service. Warranty service must be done by authorized Wallas repair personnel. The warranty does not cover costs for the removal and reinstallation of the device or for any damage in transit of a device that has been sent for repair. Warranty does not include any transport costs. (Wallas is a return to base warranty).

The customer must provide the following information in writing for warranty service:

- description of the problem.
- a description of where and how the device was installed (photographs of the installation may help)
- product type and serial number, place and date of purchase

2. This warranty is not valid in the following cases when:

- failure occurs as a result of components, which are not approved by the manufacturer, have been added to the device, and/or, it's structure has been modified without the consent of the manufacturer.
- the instructions for installation, operation or maintenance have not been followed according to this manual.
- storage or transport has been inappropriate.
- a problem has resulted from an accident or damage, which Wallas has had no control over (force majeure).
- the product has suffered from improper handling, unsuitable fuel, low voltage, excess voltage, damage due to dirt, water penetrating in to the unit or corrosion
- the device has been opened without the explicit permission of the factory/importer
- components, other than original Wallas spare parts or components, have been used in the repair of the device.
- repair by unauthorized service company

3. Warranty does not cover consumable or wear parts, which include: glow coil/plug, bottom mat or wick, fuel filter, seals.

4. Repairs carried out during the warranty period do not renew or alter the original warranty period.

5. Indirect damages arising from a defective product are not covered by this warranty.

6. This warranty is only valid for boat products that have been installed in boats and for cottage products that have been installed in cottages. The warranty does not cover Wallas products installed in vehicles or other areas.

7. This warranty does not limit rights specified in consumer protection legislation.

When making a warranty claim, the customer must provide proof that the maintenance and safety instructions have been thoroughly followed. This warranty does not apply to defects which have arisen due to carelessness in following installation, operation and maintenance instructions.

Wallas - Viking Combi

Wallas-Marin Oy

Käärkatu 4

20780 Kaarina

Finland

<http://www.wallas.com/>

Oikeudet muutoksiin pidätetään.

Vi behåller rätten att göra ändringar.

We reserve the right to changes.

Änderungen vorbehalten.

Nous nous réservons le droit de faire des changements.

Wij behouden ons het recht voor deze te wijzigen.

Ci riserviamo il diritto di apportare modifiche.

Vi reserverer oss retten til endringer.

Document number: 490607